

JOHN DEERE

TRAMOP

RY CUTTER

107

For the best service see your
JOHN DEERE DEALER
Use Only Genuine John Deere Parts

TO THE PURCHASER

Your new John Deere Gyramor Rotary Cutter is built to last. Proper care and operation will help you get the most out of it.

The many illustrations provided in your manual show you the necessary adjustments to adapt your Gyramor to all types of jobs.

Occasionally your new machine may need a part. We suggest that you take advantage of the fact that your dealer, which assures you of genuine John Deere parts and efficient service in the field or shop. Be sure and get the identification of the part required.

Study this manual carefully and keep it handy, in a safe place, for future reference.

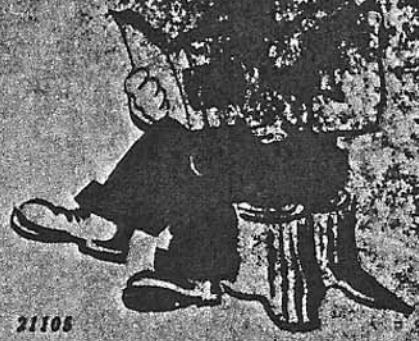

21108

JOHN DEERE GYRAMOR ROTARY CUTTER

The Gyramor Rotary Cutter has a Series Number stamped on the front upper right-hand corner of the frame. Become familiar with this Series Number and use it when ordering new parts.

DATE PURCHASED.....19.....
SERIES NUMBER.....

(To be filled in by Purchaser)

CONTENTS

	<i>Page</i>
SPECIFICATIONS.....	4
OPERATION.....	4-26
Integral Gyramor.....	5-17
Preparing John Deere Model "40" Series Tractors.....	5-7
Preparing John Deere "50," "60," and "70" Series Tractors for Integral Gyramor with Rear Gauge Wheel.....	8
Attaching Gyramor to Tractor.....	8-14
Attaching Gyramor Equipped with Gauge Shoes or Side-Mounted Gauge Wheels to John Deere Model "40" Series Tractors.....	9
Attaching Gyramor Equipped with Rear Gauge Wheel to the John Deere Models "40" Standard, "40" Tricycle, and "40" Special Tractors.....	10
Attaching Gyramor Equipped with Rear Gauge Wheel to the John Deere Model "40" Utility and Two-Row Utility Tractor.....	11
Attaching Gyramor Equipped with Gauge Shoes to John Deere Models "50," "60," and "70" Tractors with No. 800, 800A or 801 Hitch..	12
Attaching Gyramor Equipped with Side Gauge Wheels to John Deere Models "50," "60," and "70" Tractors Equipped with No. 800, 800A or 801 Hitch.....	13
Attaching Gyramor Equipped with Rear Gauge Wheel to John Deere Models "50," "60," and "70" Tractors Equipped with No. 800, 800A or 801 Hitch.....	14
Cutting Height.....	15-16
Gauge Shoe Extensions.....	17
Backing Machine.....	17
Pull-Type Gyramor.....	18-20
Preparing Tractor.....	18
Attaching Gyramor to Tractor.....	18
Powr-Trol.....	19
Locating Pins in Lift Mechanism.....	19
Cutting Height.....	20
Leveling.....	20
Changing Wheel Location.....	20
Integral and Pull-Type Gyramor.....	21-26
Discharge Grill.....	21
Removable Front Shield.....	21
Shredding Attachment.....	22
Front Shield Extension.....	22
Transporting.....	22
Gatherers.....	23
Blades.....	24
Slip Clutch Adjustment.....	25
Safety Suggestions.....	26
LUBRICATION.....	28-29
MAINTENANCE.....	30
SHIPPING BUNDLES.....	31-32
ASSEMBLY.....	33-43

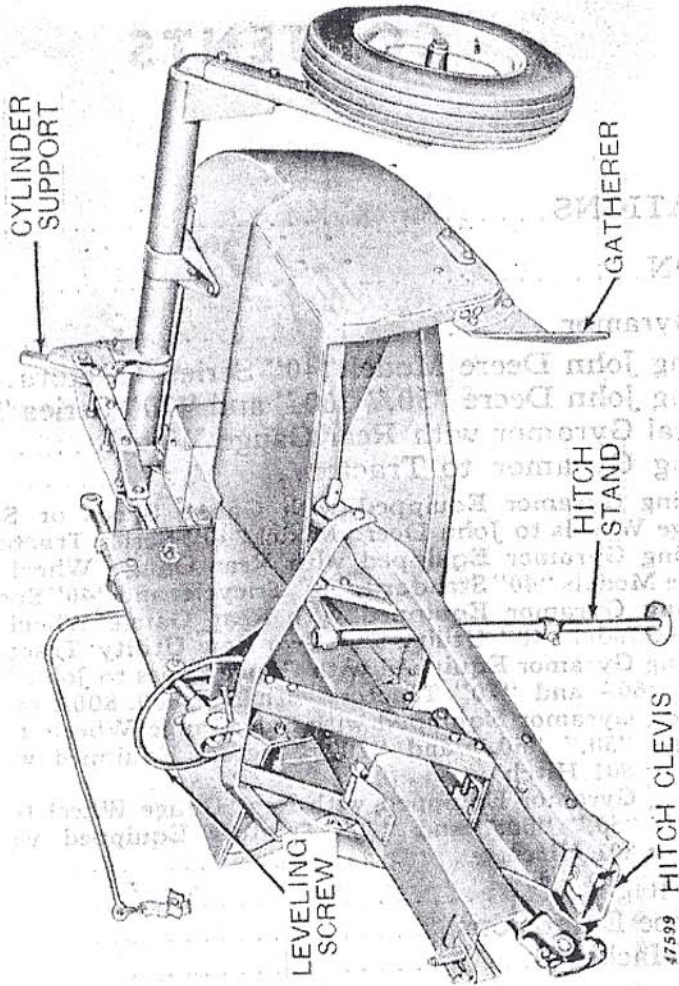

John Deere P-107 Pull-Type Gyramor Rotary Cutter

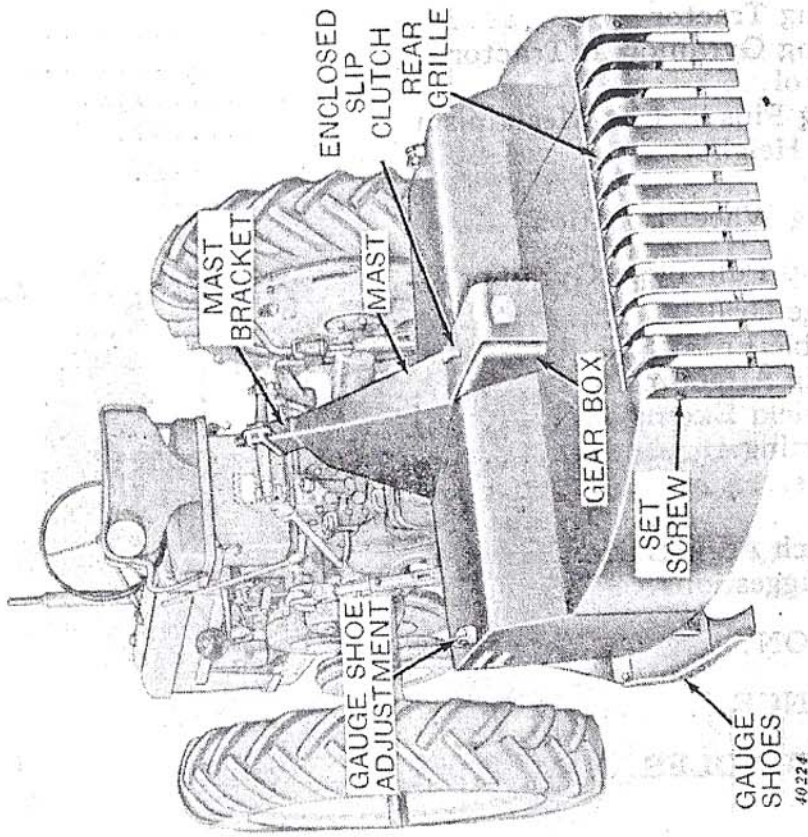

John Deere P-107 Integral Gyramor Rotary Cutter with Gauge Shoes on a John Deere Model "50" Tractor

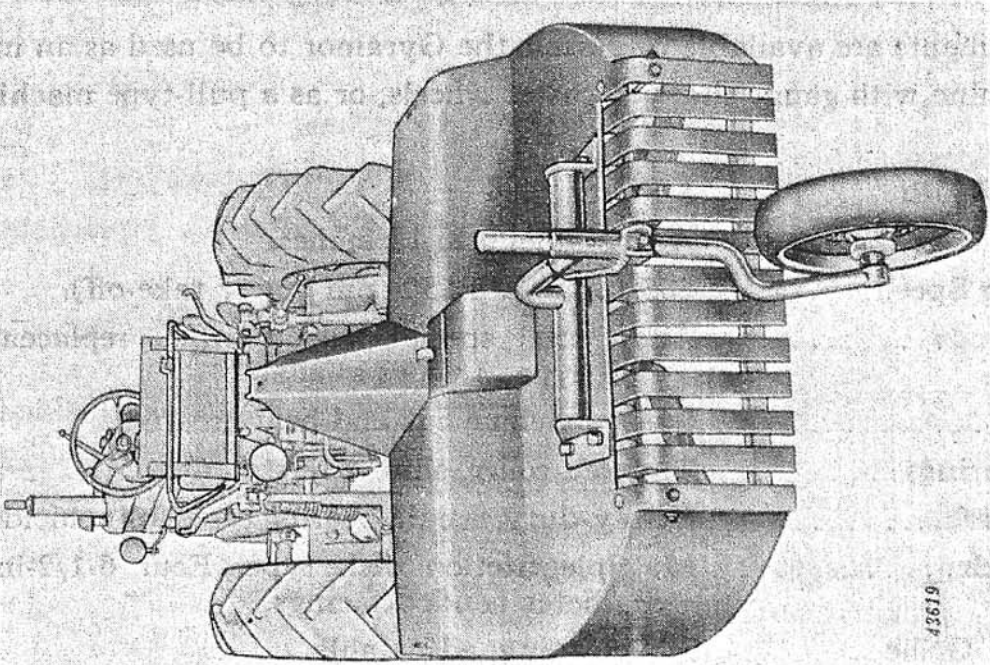

43619

John Deere P-107 Integral Gyramor Rotary Cutter Equipped with Rear Gauge Wheel, Attached to John Deere "40" Standard Tractor

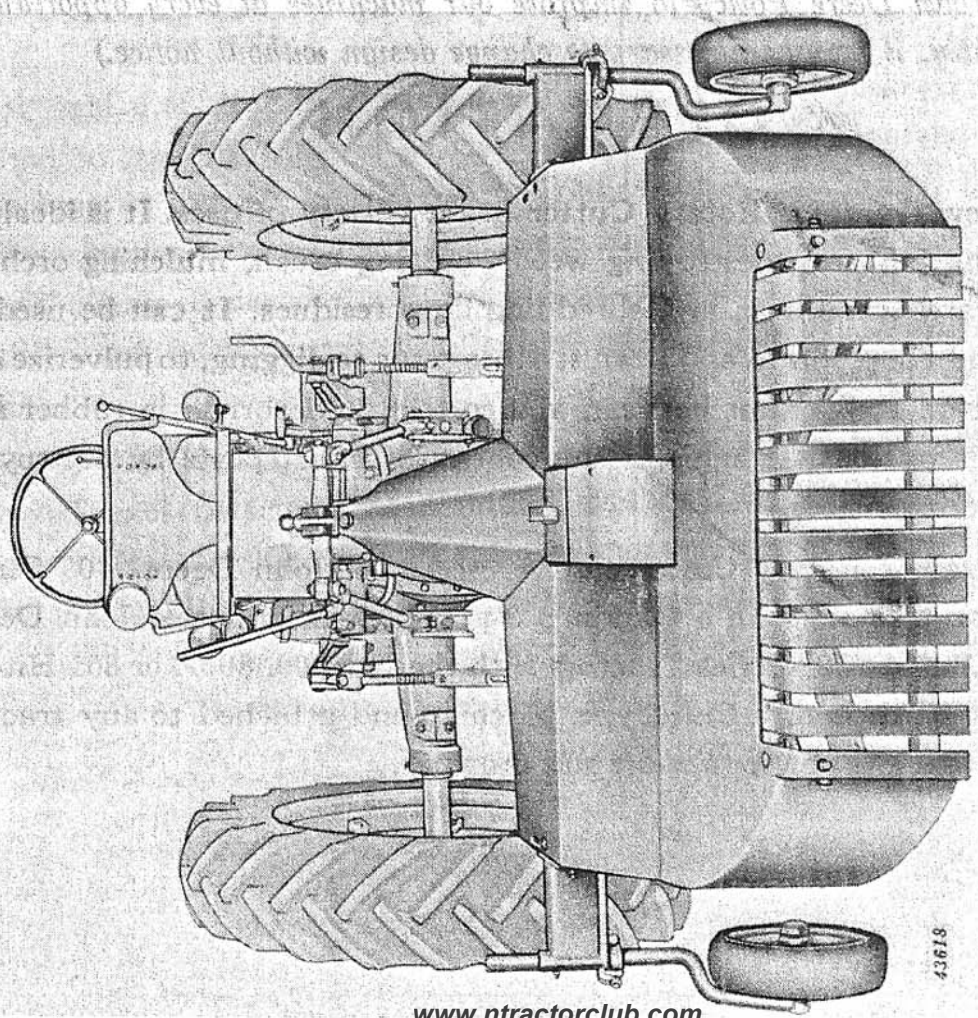

43618

John Deere P-107 Integral Gyramor Rotary Cutter Equipped with Side Gauge Wheels, Attached to John Deere "70" Tractor

SPECIFICATIONS

Attachments are available to permit the Gyramor to be used as an integral machine with gauge shoes or caster wheels, or as a pull-type machine.

Cutting Width.....	5-Foot.
Cutting Height.....	Adjustable, 0 to 14 inches.
Operating Speed.....	765 rpm (with 550 rpm power take-off).
Blades.....	Alloy steel special heat treated, replaceable flail type; 3 types available.
Gears.....	Steel, machine cut and heat treated.
Main Bearings.....	Tapered roller, shim adjustment.
Power Shaft.....	Heavy-duty, needle-bearing type, fully shielded.
Slip Clutch.....	Multiple friction disk type. Four 6-1/2-inch diameter bonded facings.
Discharge Grille.....	Self-cleaning, adjustable.
Approx. Shipping Weight	Integral—750 lbs. Pull-Type—1,350 lbs.

(It is John Deere Policy to improve our machines at every opportunity. Consequently, it may be necessary to change design without notice.)

OPERATION

Your new Gyramor Rotary Cutter has a variety of uses. It is ideal for maintaining pastures, destroying weeds, cutting brush, mulching orchard and vineyard trimmings, and shredding crop residues. It can be used to remove and chop potato and peanut vines prior to digging, to pulverize and spread cotton stalks after harvest, and to trim underbrush in rubber and coconut plantations. It helps in the control of insect pests by destroying their wintering places.

The Gyramor Rotary Cutter can be used with John Deere "40" Series and similar tractors with a standard 3-point hitch, and also John Deere "50," "60," and "70" Series Tractors with the No. 800, 800A or 801 Hitch. It can also be used as a Pull-Type Machine and attached to any tractor having a standard power take-off and drawbar.

INTEGRAL GYRAMOR

PREPARING JOHN DEERE MODEL "40" SERIES TRACTORS

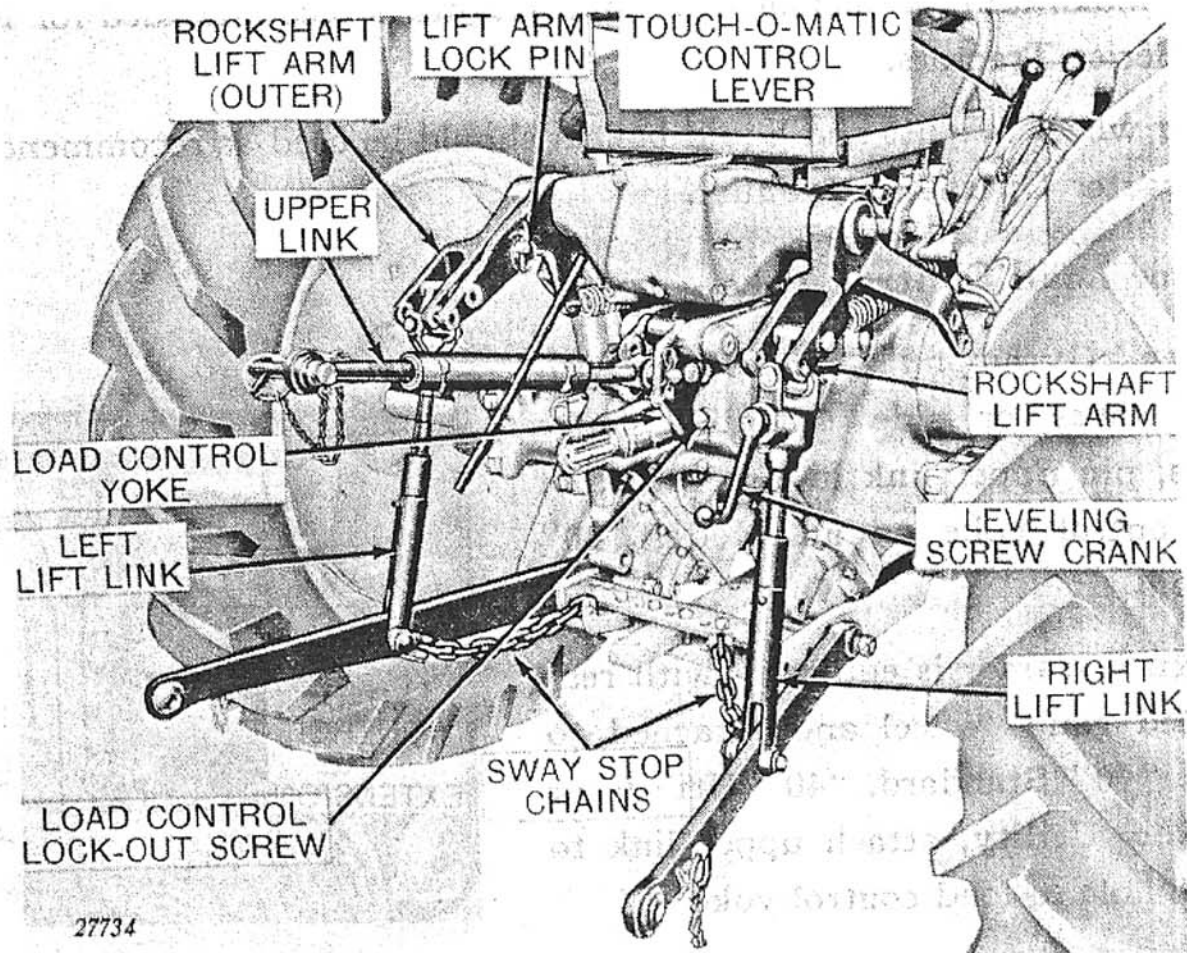

Turn out load control lock-out screw so load control will not operate.
Pin upper ends of lift links to inner holes in rockshaft lift arms.

Wheel Tread.

For the best results, the tractor wheels should be adjusted to the same tread as the gauge shoes; 62-1 2 or 76 inches, on Gyramor Rotary Cutter.

Tire Inflation.

The Tractor Operator's Manual provides information regarding front and rear wheel tire pressure.

Front End and Rear Wheel Weights.

The maximum number of front end weights is recommended for Model "40" Series Tractors.

Rear wheel weights and liquid ballast should be used as recommended in the Tractor Operator's Manual.

Tractor Load Control Yoke.

When Gyramor is equipped with gauge shoes or side mounted gauge wheels, pin upper link in upper hole of load control yoke on all Model "40" Tractors.

When Gyramor is equipped with rear mounted gauge wheel and attached to Model "40" Standard, "40" Utility, or Two-Row Utility, attach upper link to bottom hole in load control yoke.

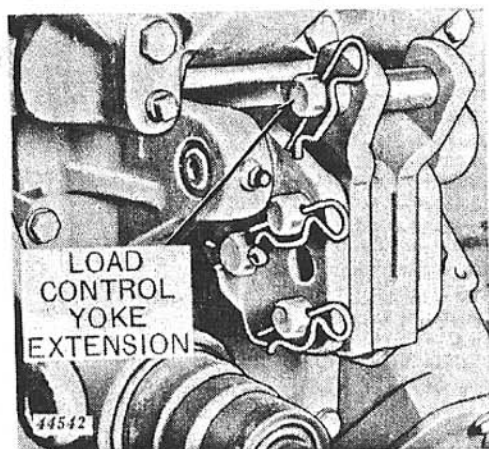

When Gyramor is attached to "40" Tricycle or "40" Special Tractor, pin load control yoke extension to tractor load control yoke and pin upper link to top hole in extension.

MODEL "40" TRICYCLE, SPECIAL, AND TWO-ROW UTILITY TRACTORS

NOTE: On the above Model "40" Tractors, the dual cylinders of the Touch-o-matic must be paralleled for all operations with this Gyramor. The following steps will accomplish this operation.

Shift touch-o-matic selector lever to forward position.

Pin left-hand rockshaft lift arms together.

Shift left-hand or inner Touch-o-matic control lever to rear position. Set the quadrant stop against the lever.

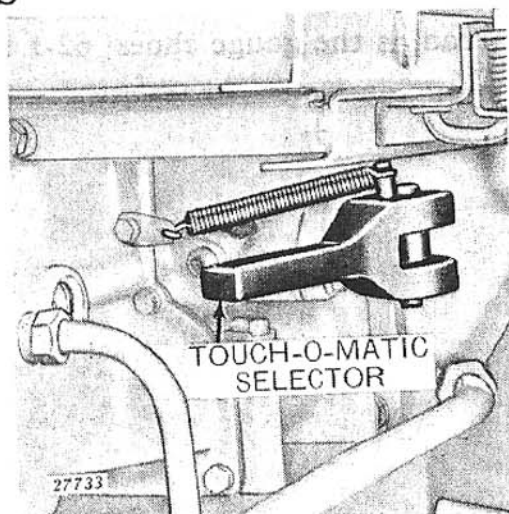

MODEL "40" TRICYCLE, SPECIAL, AND TWO-ROW UTILITY TRACTORS—Continued

Remove drawbar; pin sway chains to first hole on each side of center hole in drawbar support.

Remove cap from end of power shaft.

Install power shaft master shield supplied with tractor.

MODEL "40" STANDARD TRACTOR

Remove cap from end of power shaft.

Install power shaft shield supplied with tractor.

MODEL "40" UTILITY TRACTOR

The "40" Utility Tractor must be equipped with a standard Power Take-Off Attachment.

Remove pins and release sway chains from sway chain anchor on drawbar support.

Remove sway chain anchor provided with tractor, from drawbar support.

Install special sway chain anchor for "40" Utility Tractors Serial No. 62733 and below.

Pin sway chains to new anchor.

NOTE: Draft links on "40" Utility Tractor must be set at the "outer" position for use with Gyramor.

Remove guard from end of power shaft.

Install power shaft master shield supplied with tractor.

PREPARING JOHN DEERE "50," "60," AND "70" SERIES TRACTORS FOR INTEGRAL GYRAMOR WITH REAR GAUGE WHEEL

When used with Nos. 800, 800A or 801 Hitch

Attach quadrant assembly to L.H. rockshaft lift arm as shown. Install pipe spacer in holes in lift arm and insert plow bolts from R.H. side.

Slip depth stop finger over Powr-Trol lever.

Loosen base of Powr-Trol lever and slide lever assembly in or out until roller on depth stop arm is centered on cam surface at end of depth stop finger.

Tighten clamps.

Adjust throttle valve screw on Powr-Trol valve housing so machine lowers gently with lever in "fast drop" position. (See "Adjustment for Rockshaft Operation" in Tractor Operator's Manual.)

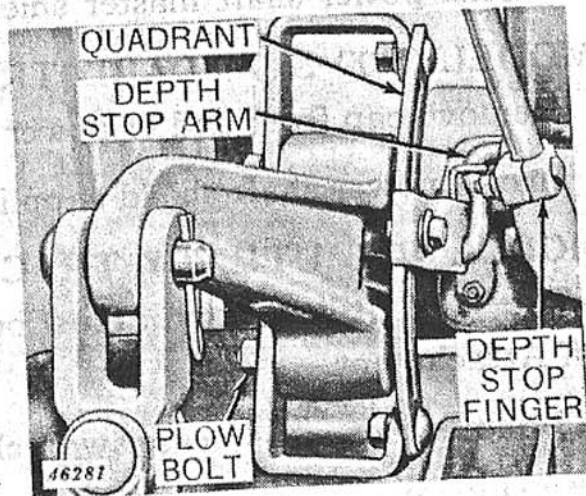

ATTACHING GYRAMOR TO TRACTOR

The procedure and equipment used to attach the Integral Gyramor to the tractor depends on the model of the tractor and whether gauge wheels or gauge shoes are used on the Gyramor. Refer to pages 9 to 14 for detailed instructions.

ATTACHING GYRAMOR EQUIPPED WITH GAUGE SHOES OR SIDE-MOUNTED GAUGE WHEELS TO JOHN DEERE MODEL "40" SERIES TRACTORS

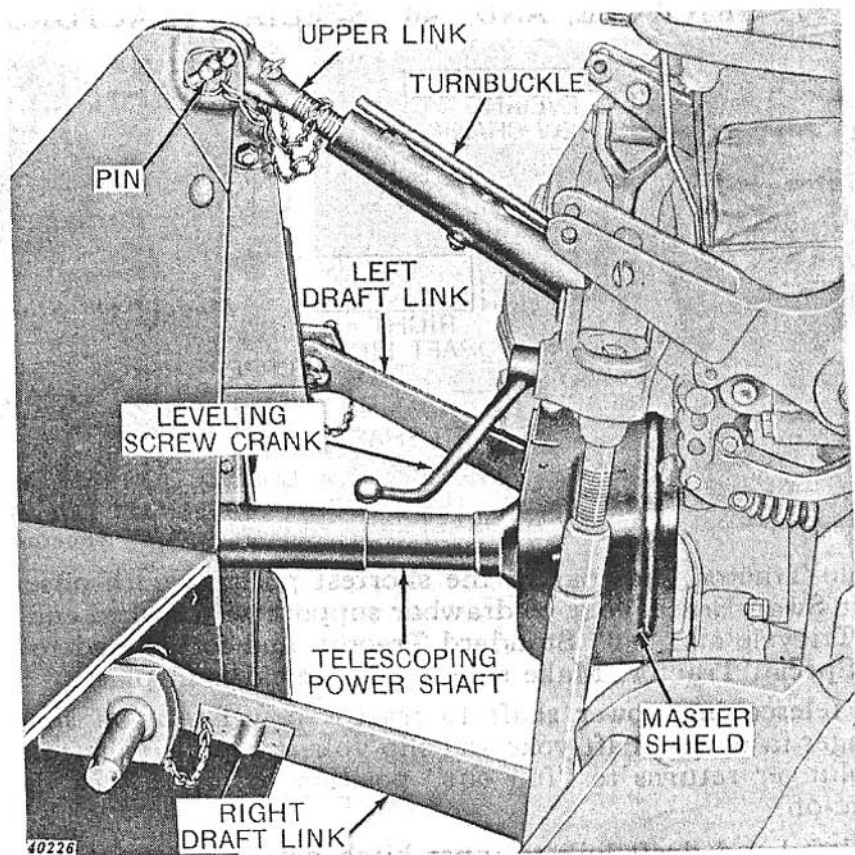

NOTE: Sway braces are required when side-mounted gauge wheels are used with Model "40" Series Tractors. Instructions for attaching them will be found on pages 10 and 11.

Back tractor until draft links are approximately in line with the draft pins on Gyramor.

Make sure power shaft master shield is in place. Attach telescoping power shaft to tractor power take-off shaft. Press in on plunger in power shaft yoke and slip yoke on splined shaft of tractor. Be sure plunger returns to "full out" position to insure lock on tractor power take-off.

Attach left draft link to left-hand inner draft pin, using Touch-o-matic control lever to align link with pin, and lock in place.

Attach right draft link to right-hand inner draft pin, using tractor leveling screw to align link with pin, and lock in place.

Attach upper link to mast. Adjust length of upper link with turnbuckle if necessary. Insert pin through upper link and mast and lock in place.

Raise Gyramor and adjust tractor leveling screw to level machine.

DETACHING FROM TRACTOR

With Gyramor gauge shoes resting on the ground, turn upper link turnbuckle until load is relieved. Detach upper link.

Detach right and left draft links.

Remove telescoping power shaft from tractor by pressing in on plunger and pulling back on power shaft yoke.

ATTACHING GYRAMOR EQUIPPED WITH REAR GAUGE WHEEL TO THE JOHN DEERE MODELS "40" STANDARD, "40" TRICYCLE, AND "40" SPECIAL TRACTORS

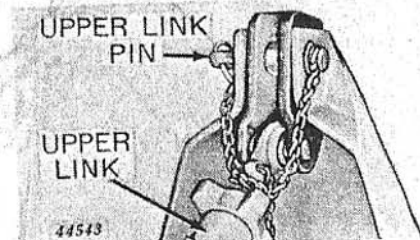
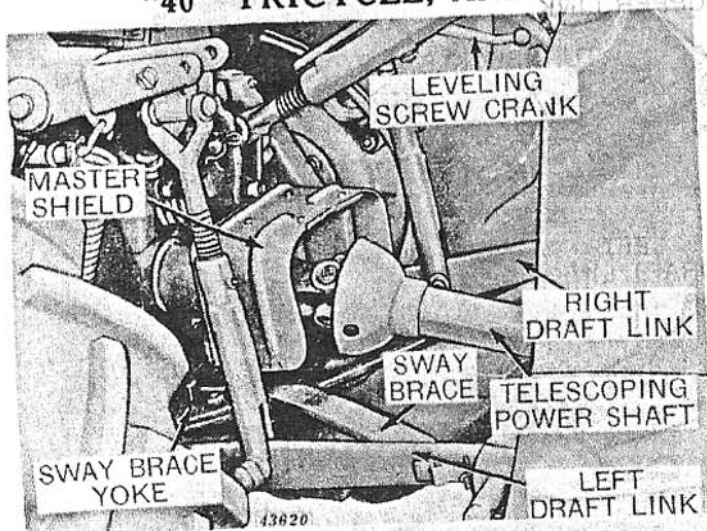

Model "40" Standard



Model "40" Tricycle and "40" Special

Assemble Tractor Drawbar in the shortest position with offset end at front. Bolt Sway Brace Yoke to drawbar support with forked end forward for "40" Tricycle and "40" Standard Tractor, and forked end to the rear for "40" Special Tractor. Make sure master shield is in place.

Attach telescoping power shaft to tractor power take-off shaft. Press in on plunger in power shaft yoke and slip yoke on splined shaft of tractor. Be sure plunger returns to "full out" position to insure lock on tractor power take-off.

Attach left-hand draft link to inner hitch pin; then attach left side of sway brace and secure with quik-lock pin.

Fasten right-hand draft link to inner hitch pin; then attach right side of sway brace and secure with quik-lock pin. Place front end of sway brace in fork on drawbar support.

Model "40" Tricycle Tractor and "40" Special Tractor.

Attach upper link to hole in top link connection and secure in place with pin and Quik-Lock pin. With machine in working position adjust length of top link so front of top link connection is carried about one-half inch above mast.

Model "40" Standard.

Attach upper link to top link connection using pin supplied with connection. Attach top link connection to mast with pin supplied with upper link.

With machine in working position, adjust length of upper link so rear of top link connection is carried about one-half inch above the mast.

Raise Gyramor and adjust tractor leveling screw to level machine.

DETACHING FROM TRACTOR.

With gauge wheel or wheels resting on the ground block up front end of machine and turn upper link until load is relieved. Remove upper link.

Detach right- and left-hand sway braces and right- and left-hand draft links.

Remove telescoping power shaft from tractor by pressing in on plunger and pulling back on power shaft yoke.

ATTACHING GYRAMOR EQUIPPED WITH REAR GAUGE WHEEL TO THE JOHN DEERE MODEL "40" UTILITY TRACTOR AND MODEL "40" TWO-ROW UTILITY TRACTOR

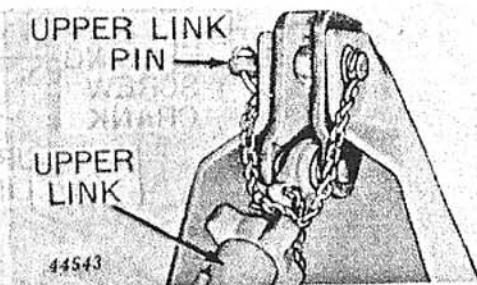
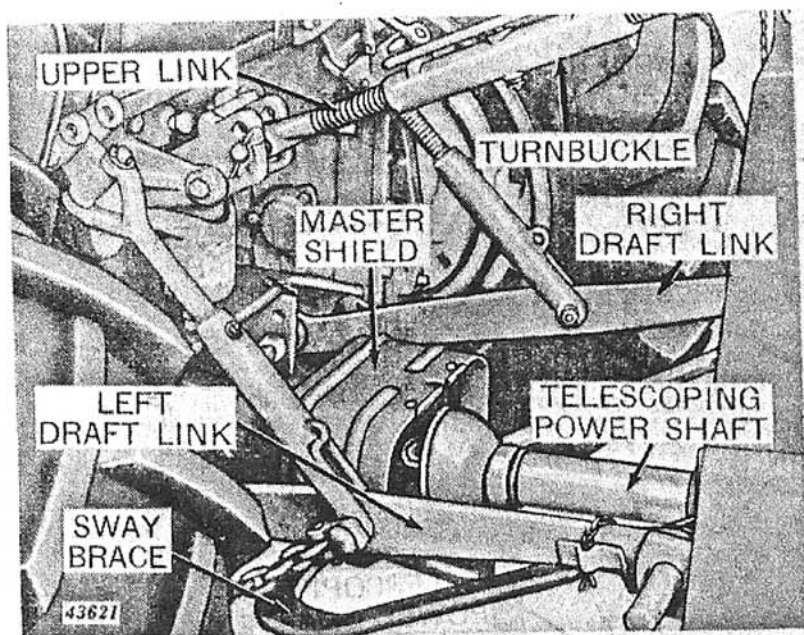

If tractor drawbar is offset type, assemble with offset end at the front. Pin drawbar on tractor center line with the rear end projecting about seven inches beyond the drawbar support. To accomplish this on tractors with Serial No. 62736 and below, drill extra hole in drawbar. Make sure power shaft master shield is in place.

Attach telescoping power shaft to tractor power take-off shaft. Press in on plunger in power shaft yoke and slip yoke on splined shaft of tractor. Be sure plunger returns to "full out" position to insure lock on tractor power take-off.

Attach left-hand draft link to inner hitch pin; then attach left side of sway brace and secure with quik-lock pin.

Attach right-hand draft link to inner hitch pin; then fasten right side of sway brace and secure with quik-lock pin. Place front end of sway brace over tractor drawbar.

Attach upper link to top link connection using pin supplied with connection. Attach top link to mast with pin supplied with upper link.

With machine in working position, adjust length of upper link so rear of top link connection is carried about one-half inch above the mast.

Raise Gyramor and adjust tractor leveling screw to level machine.

DETACHING FROM TRACTOR.

With gauge wheel or wheels resting on the ground, block up front end of machine and turn upper link until load is relieved. Detach upper link.

Detach right- and left-hand sway braces and right- and left-hand draft links.

Remove telescoping power shaft from tractor by pressing in on plunger and pulling back on power shaft yoke.

ATTACHING GYRAMOR EQUIPPED WITH GAUGE SHOES TO JOHN DEERE MODELS "50," "60," AND "70" TRACTORS WITH No. 800, 800A OR 801 HITCH

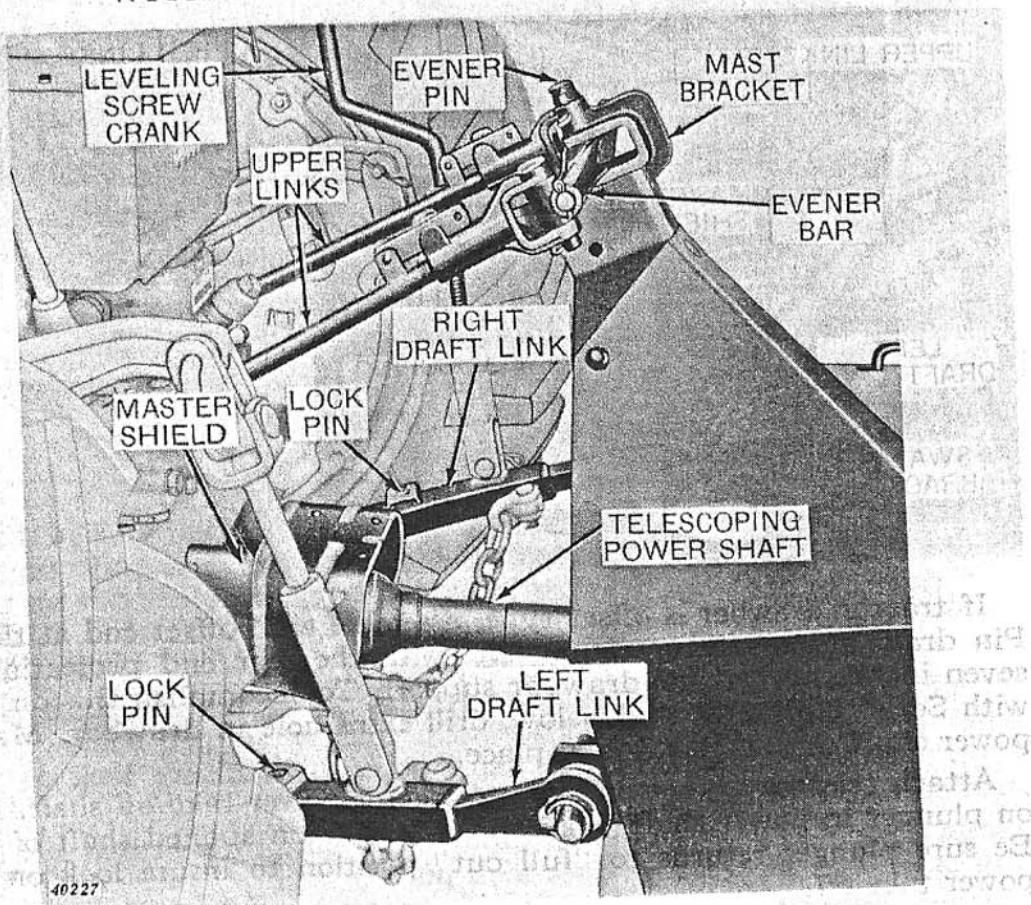

Back tractor until draft links are approximately in line with draft pins on Gyramor.

Make sure power shaft master shield is in place. Attach telescoping power shaft to tractor power take-off shaft. Press in on plunger in power shaft yoke and slip yoke on splined shaft of tractor. Be sure plunger returns to "full out" position to insure lock on tractor power take-off.

Attach left draft link to left-hand outer draft pin, using tractor Power-Trol lever to align link with draft pin, and lock in place.

Attach right draft link to right-hand outer draft pin, using tractor leveling screw crank to align link with pin, and lock in place. Removal of lock pin permits draft links to telescope and facilitates attachment.

When using the No. 801 Hitch on tractor, insert both stop pins so the bell crank linkage does not operate. See instructions in the Operator's Manual for the No. 801 Hitch.

Attach evener bar to mast bracket, using evener pin and spring locking pin. Adjust length of top link if necessary.

DETACHING FROM TRACTOR

With Gyramor gauge shoes resting on the ground, adjust upper links until load is relieved. Remove upper link.

Detach right and left draft links.

Remove telescoping power shaft from tractor by pressing in on plunger and pulling back on power shaft yoke.

ATTACHING GYRAMOR EQUIPPED WITH SIDE GAUGE WHEELS TO JOHN DEERE MODELS "50," "60," AND "70" TRACTORS EQUIPPED WITH No. 800, 800A OR 801 HITCH

Remove tractor sway chains. Bolt the tractor drawbar in the center of the drawbar support with the offset end to the rear and up. The rear end of the drawbar should project about 11-1/2 inches beyond the drawbar support. Make sure power shaft master shield is in place.

Attach telescoping power shaft to tractor power take-off shaft. Press in on plunger in power shaft yoke and slip yoke on splined shaft of tractor. Be sure plunger returns to "full out" position to insure lock on tractor power take-off.

Attach left-hand draft link to outer hitch pin and secure with quik-lock pin. Attach spacer and left-hand sway brace on inner hitch pin and secure with quik-lock pin.

Attach right-hand draft link to outer hitch pin and secure with quik-lock pin. Attach spacer and right-hand sway brace on inner hitch pin and secure with quik-lock pin. Place offset end of sway brace over tractor drawbar. Removal of lock pins permits draft links to telescope and facilitates attachment.

When using the No. 801 Hitch on tractor, insert both stop pins so the bell crank linkage does not operate. See instructions in the Operator's Manual for the No. 801 Hitch.

Attach evenèr bar to mast bracket, using evenèr pin and spring locking pin. Adjust length of top link if necessary.

DETACHING FROM TRACTOR.

With Gyramor gauge wheels resting on the ground, place block under rear end of machine. Adjust upper link until load is relieved. Remove upper link.

Detach right- and left-hand draft links and sway braces.

Remove telescoping power shaft from tractor by pressing in on plunger and pulling back on power shaft yoke.

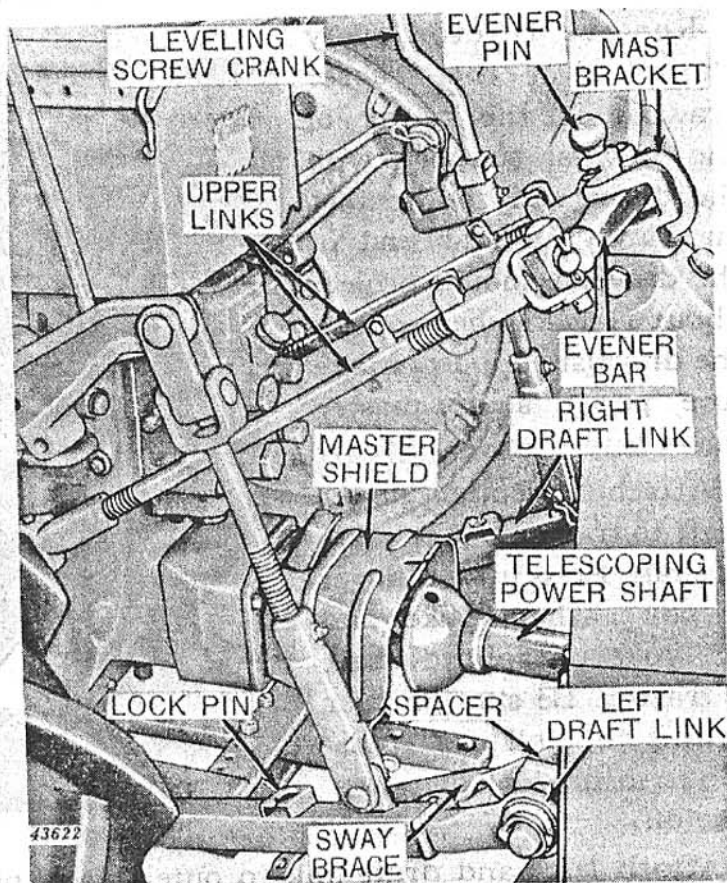

ATTACHING GYRAMOR EQUIPPED WITH REAR GAUGE WHEEL TO JOHN DEERE MODELS "50," "60," AND "70" TRACTORS EQUIPPED WITH No. 800, 800A OR 801 HITCH

Remove tractor sway chains. Bolt the tractor drawbar in the center of the drawbar support, with the offset end to the rear and up. The rear end of the drawbar should project about 11-1/2 inches beyond the drawbar support. Make sure power shaft master shield is in place.

Attach telescoping power shaft to tractor power take-off shaft. Press in on plunger in power shaft yoke and slip yoke on splined shaft of tractor. Be sure plunger returns to "full out" position to insure lock on power take-off.

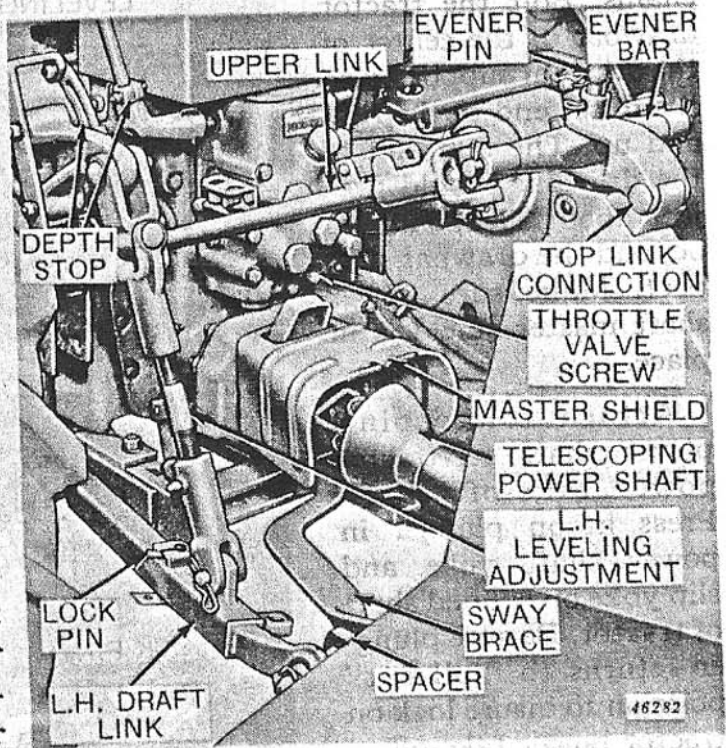

Attach left-hand draft link to outer hitch pin and secure with Quik-Lock pin. Attach spacer and left-hand sway brace on inner hitch pin and secure with Quik-Lock pin.

Attach right-hand draft link to outer hitch pin and secure with Quik-Lock pin. Attach spacer and right-hand sway brace to inner hitch pin and secure with Quik-Lock pin. Place offset end of sway brace over tractor drawbar. Removal of lock pins permits draft links to telescope and facilitates attachment.

When using the No. 801 Hitch on tractor, insert both stop pins so the bell crank linkage does not operate. See instructions in the Operator's Manual for the No. 801 Hitch.

Bolt top link connection to top of Gyramor mast. Make sure it pivots freely and seats properly on top surface of mast. Attach evener bar to top link connection.

DETACHING FROM TRACTOR

With Gyramor gauge wheel resting on ground, place blocks under front right- and left-hand side of machine. Adjust upper link until load is relieved. Remove upper link.

Detach right- and left-hand draft links and sway braces.

Remove telescoping power shaft from tractor by pressing in on plunger and pulling back on power shaft yoke.

CUTTING HEIGHT

GAUGE SHOES.

Adjustable gauge shoes provide a cutting range from 0 to 12 inches. Higher cuts can be obtained by carrying Gyramor completely on the tractor hitch.

Adjustment is made by turning the adjusting crank clockwise to decrease cutting height and counter-clockwise to increase the height. When making either adjustment, count the number of revolutions and adjust both shoes the same amount.

After adjusting, return crank handles to locked position.

Lower machine to ground and adjust length of upper link on tractor to level it.



SIDE MOUNTED GAUGE WHEELS.

The side mounted gauge wheels are adjustable to provide a cutting range from 0 to 12 inches. Higher cuts can be obtained by carrying the Gyramor completely on the tractor hitch.

Adjustment is made by loosening the clamp bolt and set screw in the axle clamp. Raise the Gyramor to the desired cutting height and lower the wheels. Swing the wheels in to about 1/2-inch from the sides of the Gyramor. Tighten axle clamp so lip is against the rear stop.

Make sure wheels do not rub frame while machine is in operation.

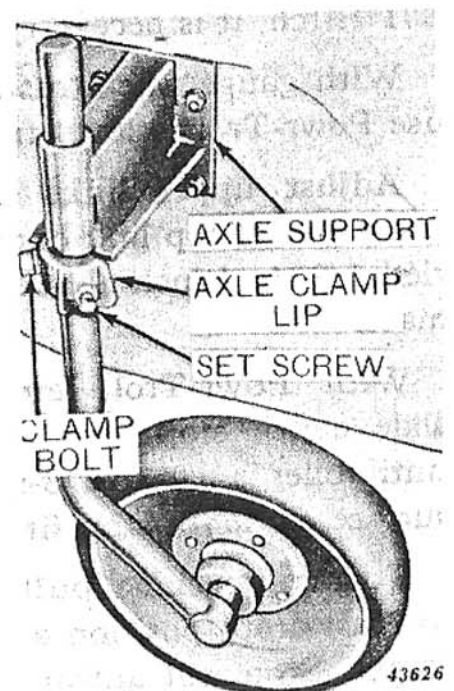

CUTTING HEIGHT—Continued

REAR MOUNTED GAUGE WHEEL.

The rear gauge wheel is adjustable to provide a cutting range from 0 to 12 inches. Higher cuts can be obtained by carrying the Gyramor completely on the tractor hitch.

Adjustment is made by loosening the set screw and bolt in the axle clamp. Raise the Gyramor to the desired cutting height and lower the wheel, retighten the clamp bolt and set screw, being sure the axle clamp lip is midway between the stops.

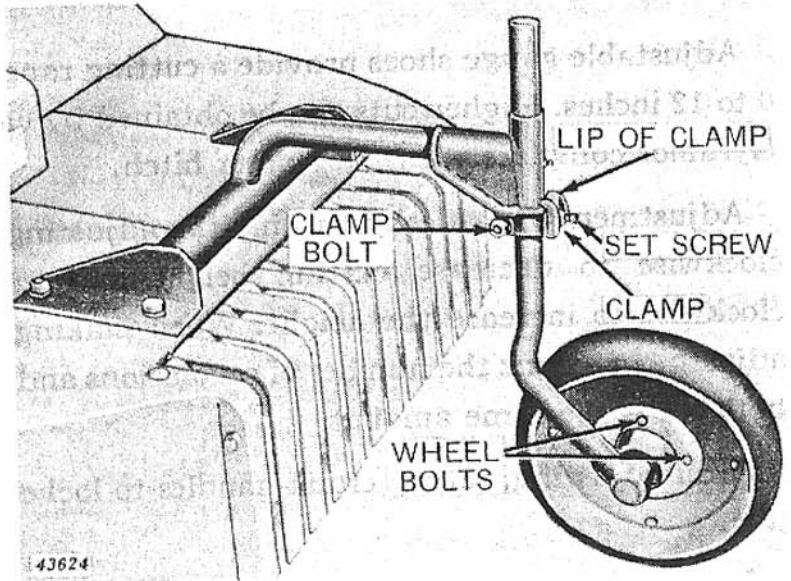

Setting Depth Stop.

When Gyramor is used with tractors equipped with Nos. 800, 800A or 801 Hitch, it is necessary to make the following additional adjustments:

With gauge wheel resting on ground and set at desired cutting height, use Powr-Trol to level front end of machine.

Adjust upper links on tractor so front end of top link connection is carried 1/2- to 1-inch above top surface of mast.

With Powr-Trol lever in neutral, slide depth stop arm along quadrant until roller is 1/2- to 5/8-inch above cam surface on depth stop finger.

To lower machine, pull lever full back to "fast drop" position and release. The Depth Stop will automatically return lever to "neutral" at the cutting height.

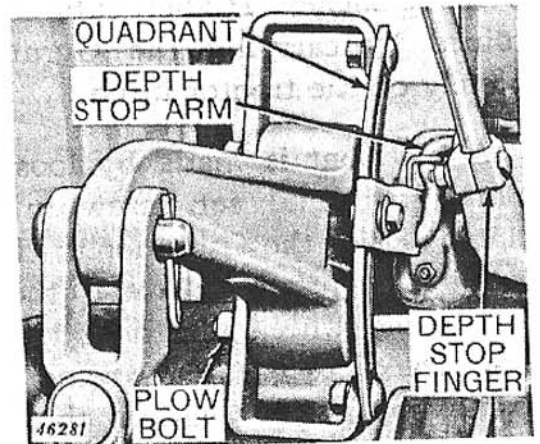

Temporary changes in cutting height may be made with Powr-Trol lever without changing the Depth Stop. Hold the lever in the "slow-raise" or "slow-drop" position until the desired height is reached.

IMPORTANT: The grille must be in the fully raised or lowered position to prevent interference between the grille bars and the rear gauge wheel.

GAUGE SHOE EXTENSIONS

NOTE: Use of the gauge shoe extensions is not recommended when the Gyramor Rotary Cutter is used with John Deere Model "40" Series Tractors.

Gauge shoe extensions will extend the width of the machine from 62-1/2 to 76 inches. When used, the machine will straddle two 38- to 42-inch rows.

BACKING MACHINE

The gauge wheels, either side or rear-mounted, do not pivot completely around. To prevent serious damage to the tires, always raise the machine off the ground before backing up.

SAFETY



FIRST

PULL-TYPE GYRAMOR

PREPARING TRACTOR

The Pull-Type Gyramor can be attached to any tractor having a drawbar and PTO shaft that conforms to ASAE-SAE standards. If necessary, conversion parts should be purchased for tractors which do not conform to these standards.

The tractor drawbar should be in the extended position, and measure approximately 14 inches from end of the PTO shaft to hitch pin hole in drawbar. Bolt drawbar in line vertically with center of tractor PTO shaft. Distance between top of drawbar and PTO shaft should be from 6 to 15 inches.

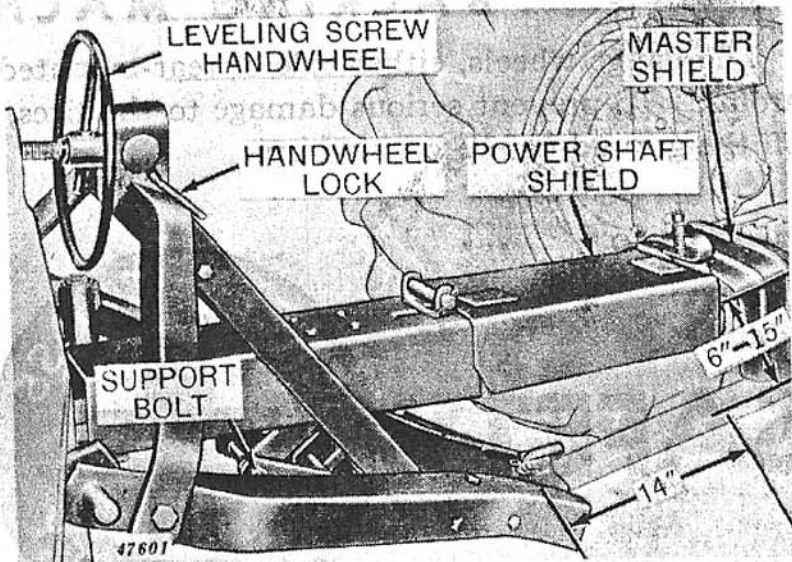

ATTACHING GYRAMOR TO TRACTOR

Lower Gyramor hitch stand.

Attach tractor drawbar to hitch clevis. Use Gyramor hand wheel to align drawbar with hitch clevis. Insert hitch pin, being sure it seats properly and insert spring locking pin. Place spoke in hand wheel between hand wheel lock.

Attach telescoping shaft to tractor PTO shaft. Press in on plunger in power shaft yoke on splined shaft of tractor. Be sure plunger returns to "full out" position to insure lock on tractor power take-off. Attach Gyramor power shaft shield to tractor master shield.

The power shaft should be as straight as possible. It can be adjusted by loosening shield support bolt in the support straps. Line up power shaft and retighten bolt.

DETACHING GYRAMOR FROM TRACTOR

Detach front end of Gyramor power shaft shield from tractor master shield and fold back, free of power shaft. Remove telescoping power shaft by pressing in on plunger and pulling back on power shaft yoke. Lower hitch stand and by use of hand wheel, relieve load from drawbar. Remove spring locking pin and hitch pin from drawbar.

POWR-TROL

The Pull-Type Gyramor is equipped for hydraulic operation with John Deere Powr-Trol or the hydraulic system of any tractor, having sufficient capacity and using an 8-inch stroke remote cylinder that conforms with ASAE-SAE standards. It can also be operated behind tractors not equipped with Powr-Trol by using a hand lift screw jack.

LOCATING PINS IN LIFT MECHANISM WHEELS AT REAR OF GY- RAMOR

When operating the Gyramor with wheels at the rear of machine, locate pins "A" and "B" as illustrated. When removing cylinder or screw jack, extend the lift mechanism as far as possible. Remove pin "B" and insert it through pivot block "C" and hole in lift rod.

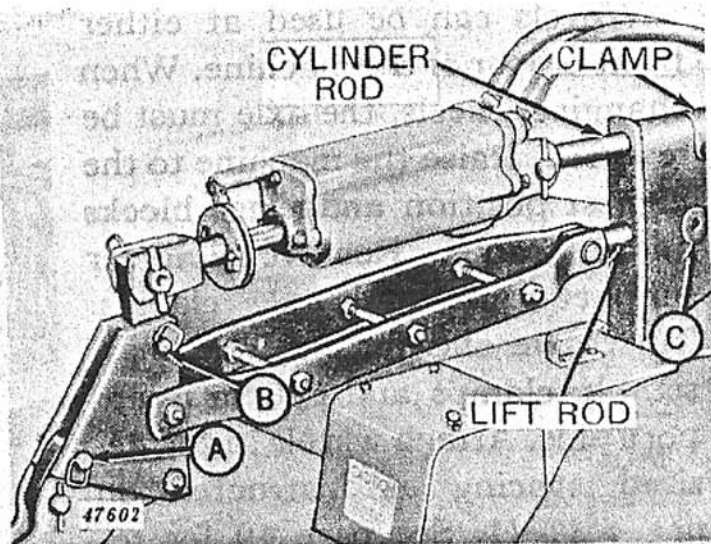

Aligning Holes.

If hole in lift rod does not line up with pivot block "C," raise machine as high as possible, block up securely, and remove cylinder or screw jack. Loosen bolt through clamp and turn cylinder rod in or out as required to line up holes at "C." Tighten clamp bolt securely.

WHEELS AT FRONT OF GY- RAMOR

When operating Gyramor with wheels at the front of machine, locate pins "A" and "B" as illustrated. When removing cylinder or screw jack, extend the lift mechanism as far as possible. Remove pin "A" and insert through holes "C."

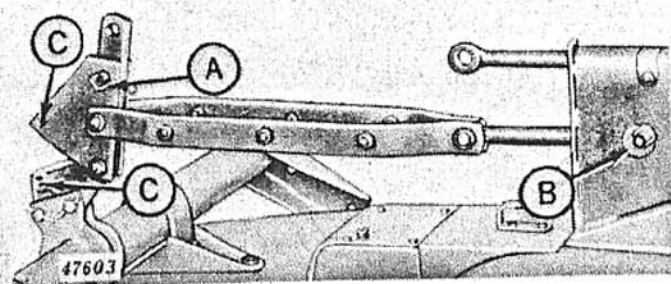

CAUTION: Do not use pins in holes "A," "B," and "C" at the same time because machine will be damaged when cylinder is operated. One of the three holes must be empty at all times.

CUTTING HEIGHT

The cutting height of the Pull-Type Gyramor is regulated by the Power-Trol cylinder or hand lift screw jack.

LEVELING

Adjust leveling screw, as necessary, to level machine when in operation.

CHANGING WHEEL LOCATION

Wheels can be used at either front or rear of the machine. When changing wheels, the axle must be reversed. Raise the machine to the highest position and place blocks under frame. Remove cylinder support pins and axle clamps. Turn axle end for end and reassemble clamps and cylinder support pins. Attach wheels in the desired spacing as instructed on pages 39-41. See page 19 for re-locating pins in lift mechanism.

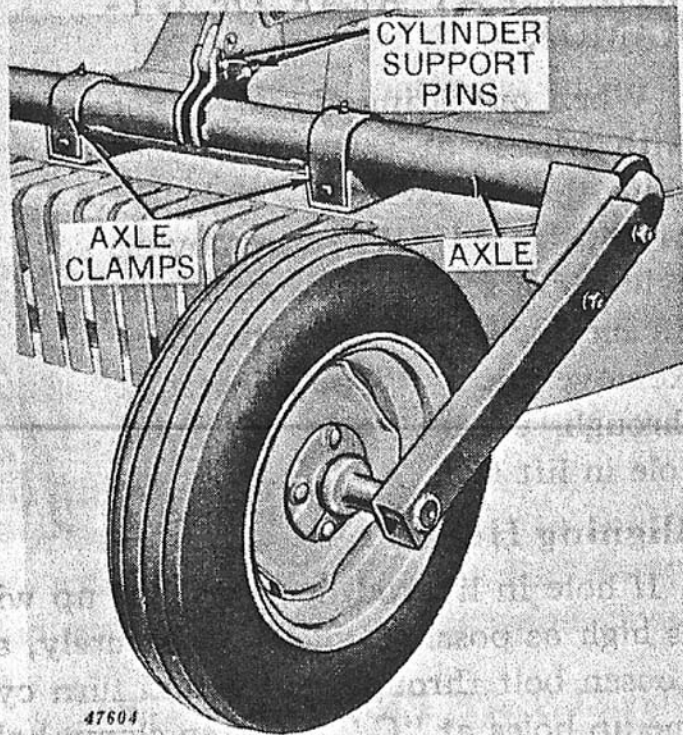

INTEGRAL AND PULL-TYPE GYRAMOR DISCHARGE GRILLE

The discharge grille is adjustable to suit a variety of crop and field conditions. Generally, it should be used in the lowered position, but for heavy cutting when material tends to build up and overload tractor. It may be opened to eliminate clogging.

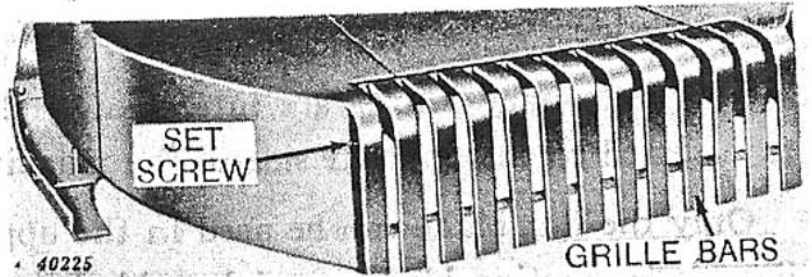

Adjustment is made by loosening jam nut and set screw at each side of grille frame.

Grasp outer grille bars and raise grille to desired setting.

Retighten set screws and jam nuts.

CAUTION: Do not adjust grille while blades are in motion.

REMOVABLE FRONT SHIELD

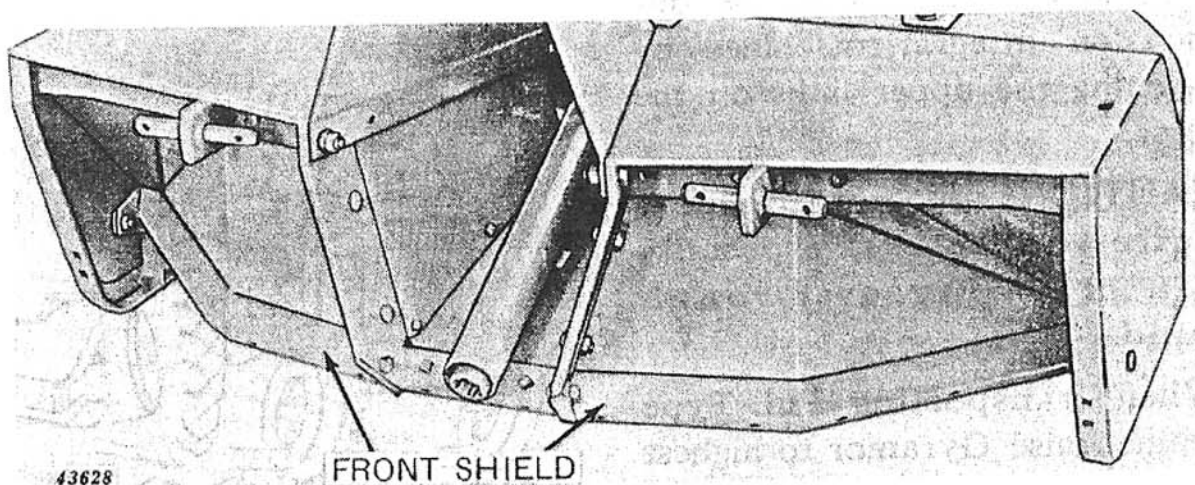

The front shield is for the operator's protection but it can be removed when working in conditions where the machine operates more efficiently without it.

SHREDDING ATTACHMENT

NOTE: Use of the shredding attachment is not recommended when the Gyramor Rotary Cutter is used with John Deere Model "40" Series Tractors.

The shredding attachment adapts the machine for extra fine chopping. The rotating knives straddle stationary knives tripling the number of cutting edges.

The stationary knives are interchangeable. When worn, they may be transferred to the opposite side of the machine, to use a new cutting edge.

Only the flat blade can be used in the upper position on the rotor. The flat blade, suction blade, or pickup blade may be used in the lower position. (See Page 42.)

FRONT SHIELD EXTENSION

This extension is available for use in conditions where there is an excessive discharge of stones and trash out the front of the machine and to keep down dust and chaff in dry cuttings.

This extension is available for use when the operator may be working in conditions where small stones are in abundance.

TRANSPORTING

Additional height may be obtained on integral machines by shortening the upper links on the tractor.

CAUTION: Do not transport at excessive speeds, especially when traveling over rough ground.

When transporting Pull-Type machine, raise Gyramor to highest position with hydraulic cylinder or screw jack.



40234

GATHERERS

Gatherers can be used in row crops to help bring down or outlying material into the path of the blades. The Gatherers can be adjusted vertically by loosening bolt and moving point of Gatherers up or down.

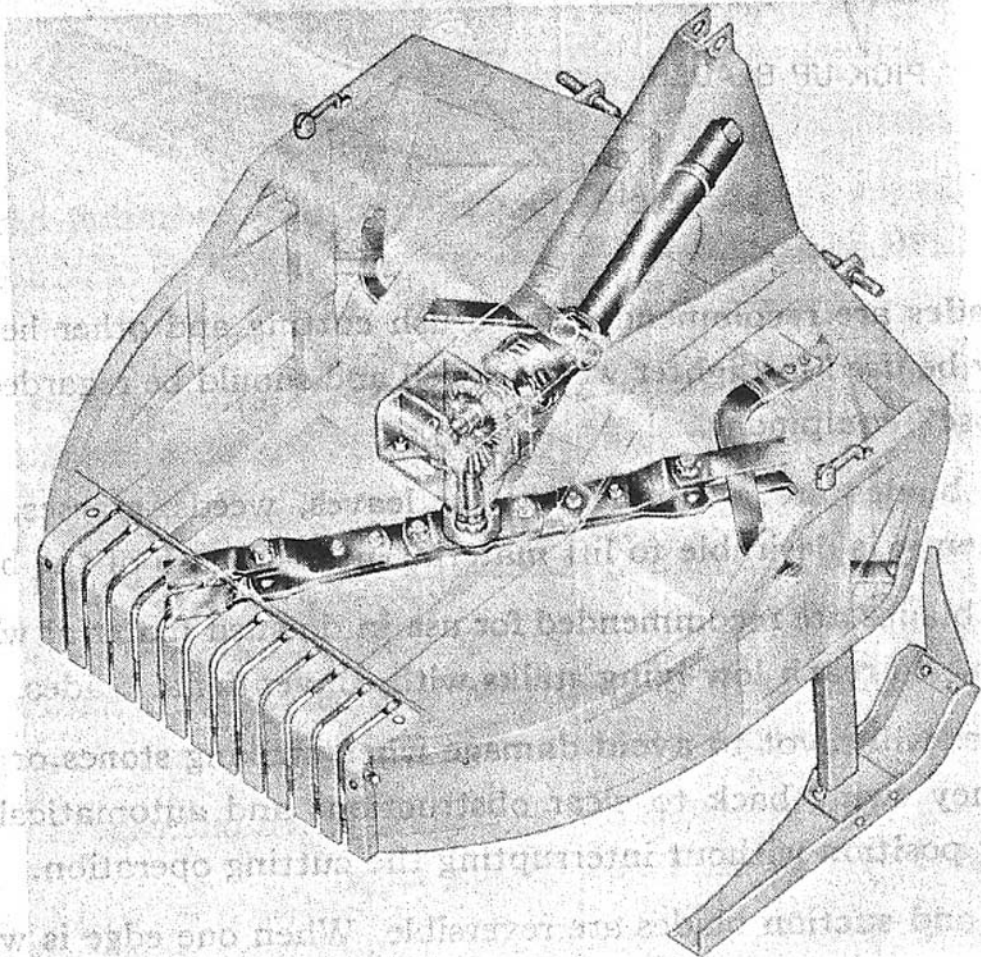
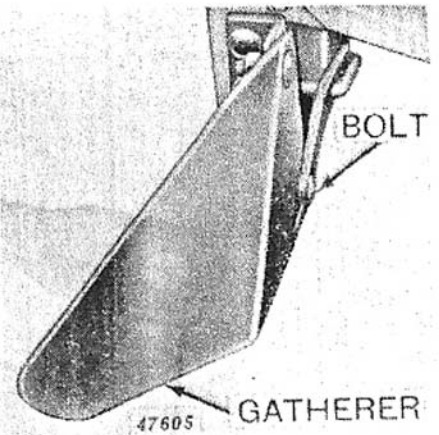

Operating Parts of the Gyramor Are Shown in the Above Illustration
www.ntractorclub.com

BLADES

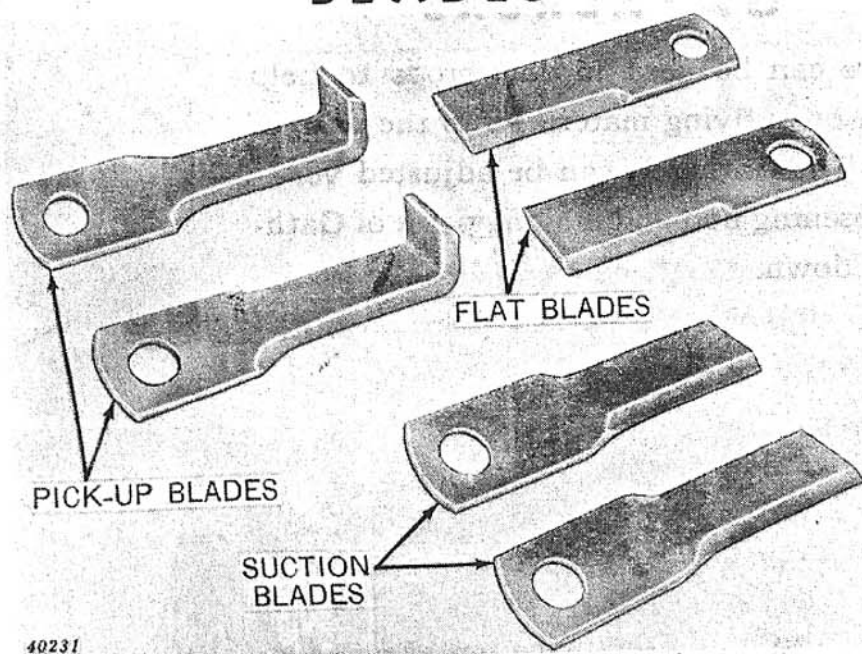

Flat blades are recommended for brush cutting and other heavy work. They may be used for lighter work as well and should be regarded as "general-purpose" equipment.

Suction blades are recommended for leaves, weeds, grasses, and trimmings, when it is desirable to lift material into the path of the blades.

Pick-up blades are recommended for use in downed material whenever it is impossible to reach low-lying stalks with conventional blades.

All blades will pivot to avoid damage when striking stones or other obstacles. They swing back to clear obstructions and automatically return to working position without interrupting the cutting operation.

The flat and suction blades are reversible. When one edge is worn, they may be turned over to use a new cutting edge.

After severe service, the knives will require replacement. New blades should always be installed in pairs to keep rotor and blades in balance and avoid vibration.

When Gyramor is first put into operation, blade and knife arm bolts should be retightened after one hour of operation, then retightened daily until all slack has been taken up.

Only one bolt need be removed to replace or reverse each blade. Check bolts for wear and, if necessary, replace them with new ones. Make sure blade attaching bolts are tight and cotter pins are in place and properly

SLIP CLUTCH ADJUSTMENT

The Gyramor clutch is properly run in and adjusted when it leaves the factory. With extensive use, however, it must be drawn up one or two notches periodically to compensate for facing wear and to maintain full capacity. The frequency of readjustment will depend on the size of tractor being used and the type of work being done. Should it run continuously hot with the tractor operating at normal load, the clutch is slipping excessively and must be reset immediately to avoid permanent damage.

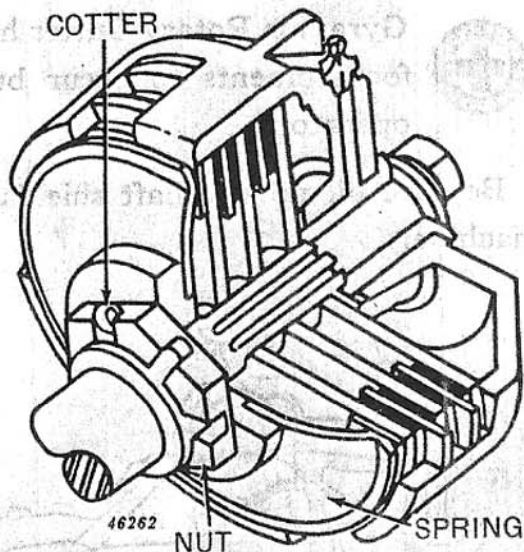

When assembling or readjusting the Gyramor slip clutch, the following is a simple and effective method of obtaining the correct torque setting: Loosen the clutch adjusting nut until the saucer-shaped clutch spring is just free enough to turn by hand; then, tighten nut 2-3/4 turns (equivalent to 16-17 flats on hex. portion of nut). Align hole in shaft with nearest slot in nut and insert cotter. The clutch spring is designed to produce maximum torque in the clutch at this setting. If the nut is tightened beyond this point the spring will start to collapse and the capacity of the clutch will gradually decrease until the spring finally snaps over center and turns inside out. Should this occur, the spring may be snapped back into shape by applying pressure in a press or vise.

When a clutch has been taken apart and reassembled it is necessary to slip it a few times to reseal the facings before it will build up to full capacity. This may be accomplished by starting the machine suddenly several times until the clutch becomes warm, or by breaking the clutch in gradually on progressively heavier work.

In damp weather, the clutch facings tend to absorb moisture which reduces the capacity of the clutch. Under these conditions, it is recommended that the clutch be slipped a few times before starting work in order to dry out the facings and restore the clutch to full capacity.

If the Gyramor has been idle for an extended period the slip clutch should be checked before putting the machine back in operation. Back off clutch adjusting nut and make sure that the clutch plates are free. Retighten as outlined above.

SAFETY SUGGESTIONS

All rotary cutters are potentially dangerous machines. The Gyramor Rotary Cutter has been designed to minimize the chance for accidents to occur but there is no substitute for a careful operator.



Be sure all power shaft shields are securely in place before operating machine.

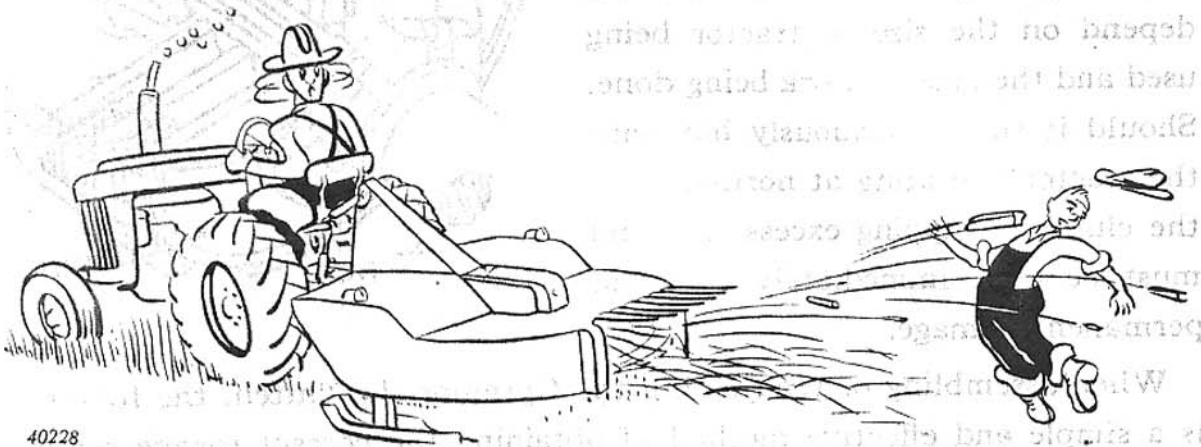

Do not, under any circumstance, operate the machine when others are standing in close range. Stones and cuttings can be thrown more than one hundred feet by the machine, when in operation.

Do not clean, lubricate, or make any adjustments to machine while in motion. Disengage power shaft and shut off tractor before working on blades or grille.

Retighten all bolts periodically. Make sure cotter pins in slotted nuts are in place and properly spread.

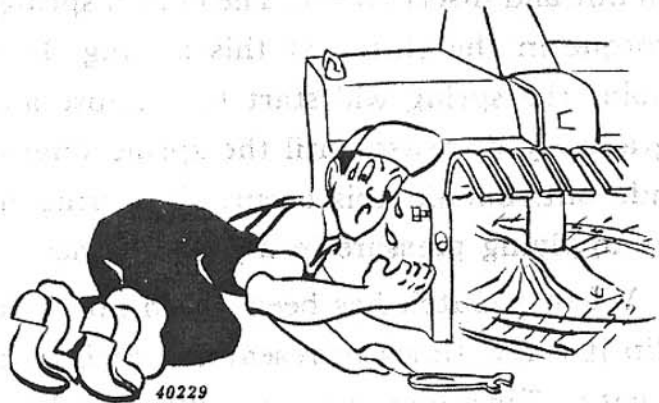

Do not ride, or permit others to ride on the tractor or implement, unless the person is on the seat or platform provided for the operator.

Be careful when operating on hillsides because the tractor may tip sideways if it strikes a hole, ditch, or other irregularity.

Use warning flags and/or lights when transporting machine on the highway.

LUBRICATION

Gear Box.

Remove dip stick and check oil level after every 48 hours of operation. Refill to top of small gear, when necessary, with a good grade of No. 140 Hypoid gear oil.

Telescoping Shaft.

Pack grease in telescoping shaft after every 48 hours of operation.

Wheels.

Pack wheel hubs with grease once a year.

CAUTION: Do not overlubricate slip clutch housing.

LUBRICATION SYMBOLS



Grease every 8 hours of operation.



Oil every 8 hours of operation.

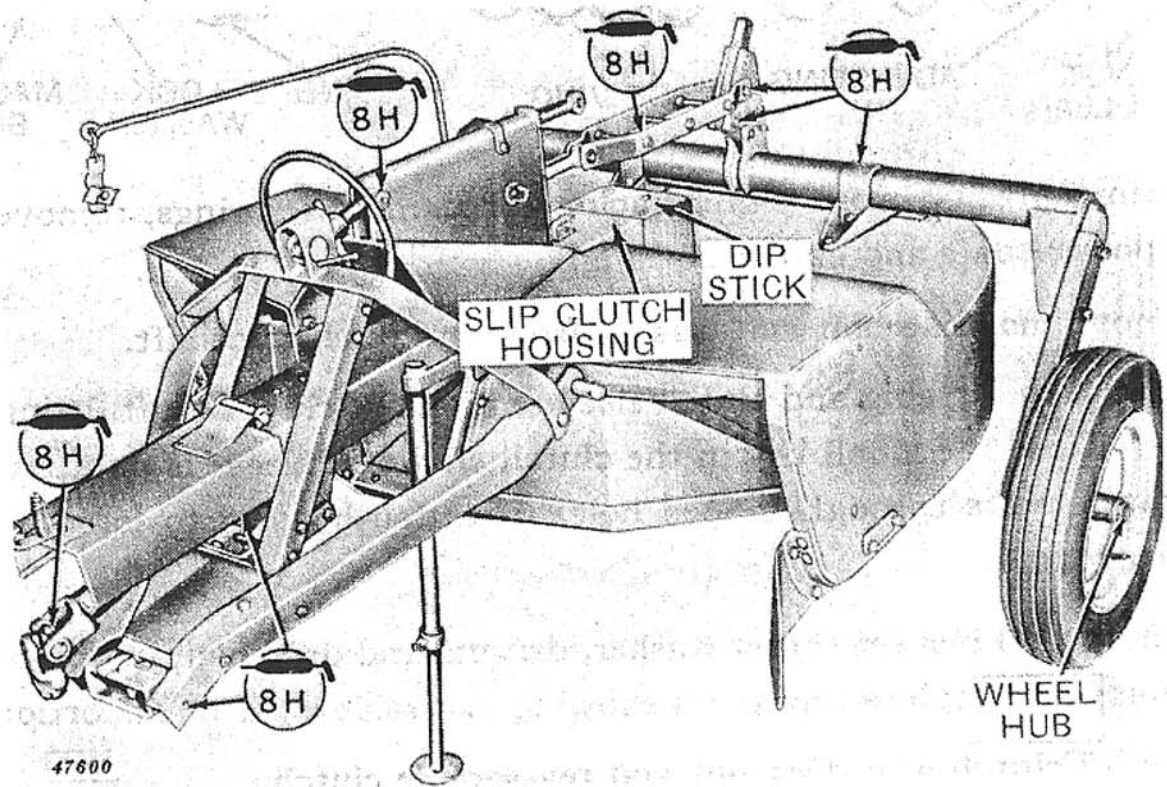
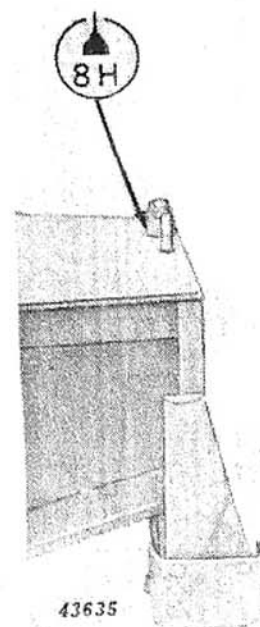
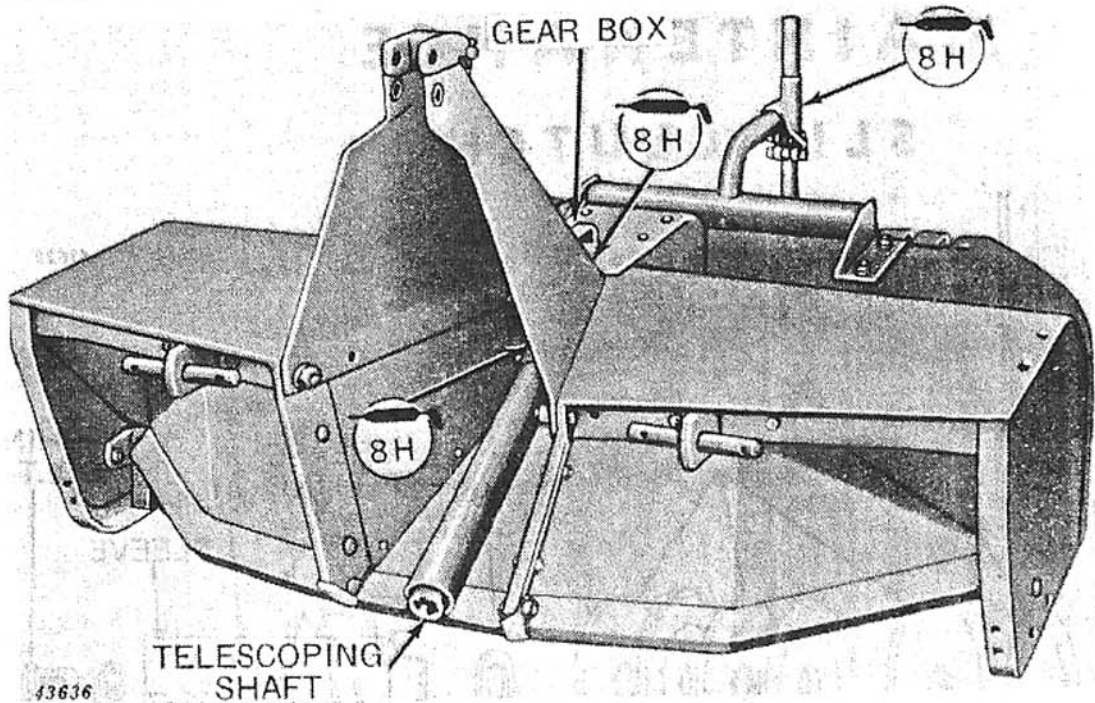

MAINTENANCE

SLIP CLUTCH

43629

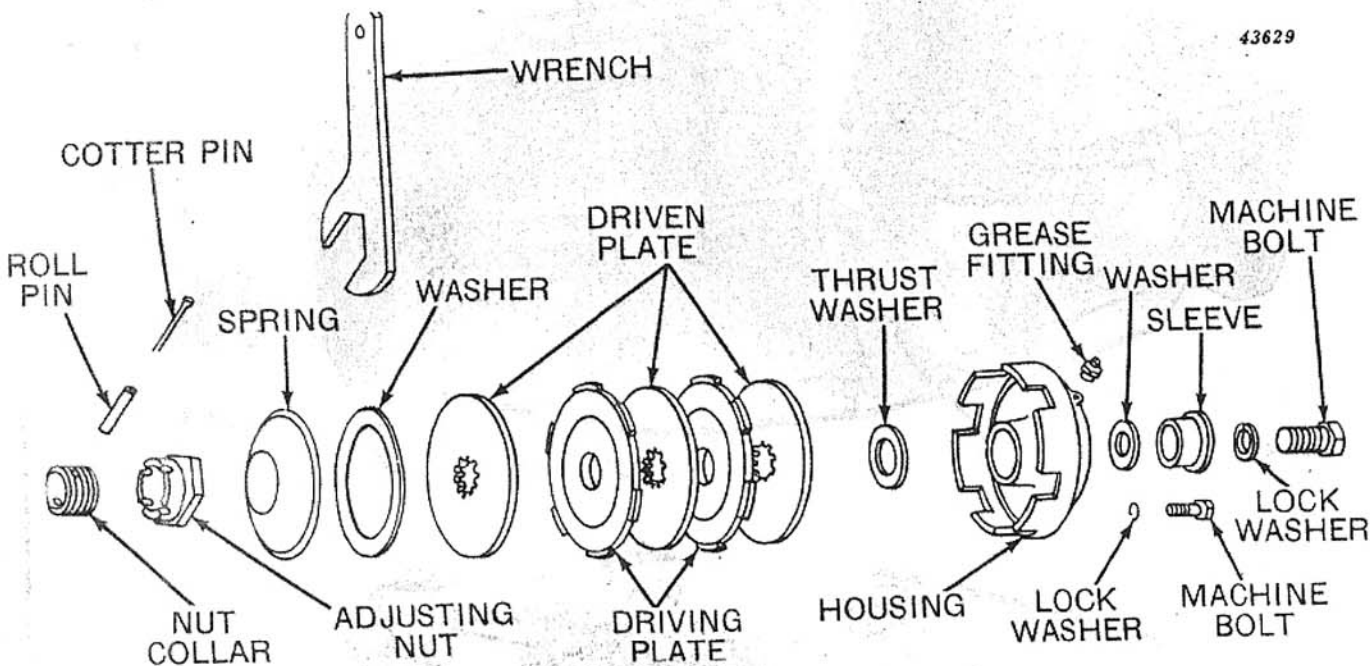

When replacing worn clutch facings or damaged springs, remove bolts from power shaft and clutch housing.

Remove machine bolt and washer from end of clutch shaft.

Pull clutch housing and clutch sleeve off end of clutch shaft, being careful not to lose the small key in the clutch sleeve. If sleeve is tight on shaft, screw long bolts through tapped holes in clutch housing to force housing and sleeve free.

Remove and inspect thrust washer, driving and driven clutch plates and clutch spring. Replace any parts showing excessive wear or distortion.

Back off clutch adjusting nut and reassemble clutch.

CAUTION: The clutch spring is designed to produce a maximum of 500 ft. lbs. torque. Overtightening will decrease clutch capacity and may permanently damage spring.

To adjust slip clutch, see page 25.

SHIPPING BUNDLES

INTEGRAL GYRAMOR FOR JOHN DEERE "40" SERIES TRACTORS AND JOHN DEERE TRACTORS WITH No. 800, 800A OR 801 HITCH

REGULAR EQUIPMENT

SGY 17 W	Frame
AGY 6 W	Mast
AGY 42 W	Power Shaft (1-3/8" Spline) (Optional)
AGY 43 W	Set of Flat Blades (Optional)

For Gyramor with Gauge Shoes—Add:

	<u>"40" Standard</u>	<u>"40" Utility, "40" Two-Row Utility</u>	<u>"40" Special, "40" Tricycle</u>	<u>800-800A-801 Hitch</u>
Gauge Shoes.....	SGY 7 W	SGY 7 W	SGY 7 W	SGY 7 W
Top Link Connection.....			SGY 16 W
Mast Bracket.....				AGY 29 W

For Gyramor with Side Caster Gauge Wheels—Add:

	<u>"40" Standard</u>	<u>"40" Utility, "40" Two-Row Utility</u>	<u>"40" Special, "40" Tricycle</u>	<u>800-800A-801 Hitch</u>
Support for Side Caster Wheels....	SGY 9 W	SGY 9 W	SGY 9 W	SGY 9 W
Caster Wheel Axle (2 used).....	SGY 12 W	SGY 12 W	SGY 12 W	SGY 12 W
Wheel with Tire (2 used).....	SGY 13 W	SGY 13 W	SGY 13 W	SGY 13 W
Sway Brace.....	SD 2246 A	AGY 85 W	SD 2246 A	SGY 10 W
Top Link Connection.....			SGY 16 W
Mast Bracket.....				AGY 29 W

For Gyramor with Rear Caster Gauge Wheel—Add:

	<u>"40" Standard</u>	<u>"40" Utility, "40" Two-Row Utility</u>	<u>"40" Special, "40" Tricycle</u>	<u>800-800A-801 Hitch</u>
Support for Rear Caster Wheel....	AGY 79 W	AGY 79 W	AGY 79 W	AGY 79 W
Caster Wheel Axle..	SGY 12 W	SGY 12 W	SGY 12 W	SGY 12 W
Wheel with Tire....	SGY 13 W	SGY 13 W	SGY 13 W	SGY 13 W
Sway Brace.....	SD 2246 A	AGY 85 W	SD 2246 A	SGY 10 W
Top Link Connection	AGY 78 W	AGY 78 W	SGY 15 W
Depth Stop and Top Link Connection.....				SGY 19 W

OPTIONAL EQUIPMENT

- AGY 41 W Power Shaft for 1-1/8" Splined Shaft (In Lieu of AGY42W)
 AGY 44 W Set of Suction Blades (In Lieu of AGY43W)
 AGY 45 W Set of Pick-Up Blades (In Lieu of AGY43W)

SPECIAL EQUIPMENT

- SGY 4 W Gauge Shoe Tread Extension
 SGY 5 W Front Shield Extension
 SGY 14 W Gatherer (Requires Gauge Shoe Tread Extension (SGY4W) when used with Gauge Shoes)
 SGY 18 W Shredding Attachment

PULL-TYPE GYRAMOR**REGULAR EQUIPMENT**

- SGY 17 W Frame
 SGY 20 W Axle
 SGY 21 W Lift Parts
 SGY 22 W Hitch
 SGY 23 W Power Shaft and Shield
 AGY 87 W Universal Joint Hook-Up—1-3/8" Spline
 JD 1384 A Wheel less Tire and Tube (2 used) (Optional)
 AGY 43 W Set of Flat Blades (Optional)

OPTIONAL EQUIPMENT

- SD 2410 A Wheel with Tire and Tube (2 used) (In Lieu of JD1384A)
 AGY 44 W Set of Suction Blades (In Lieu of AGY43W)
 AGY 45 W Set of Pick-Up Blades (In Lieu of AGY43W)

SPECIAL EQUIPMENT

- SGY 5 W Front Shield Extension
 SGY 14 W Gatherers
 SGY 18 W Shredding Attachment
 SD 2314 A Hand Screw Lift Jack

ASSEMBLY

Read all assembly instructions carefully and pay particular attention to the illustrations.

Cut all bundling wire and arrange parts conveniently.

Check oil level in gear case. If necessary, fill to top of small gear with a good grade of No. 140 Hypoid Gear Oil.

INTEGRAL GYRAMOR POWER SHAFT AND MAST

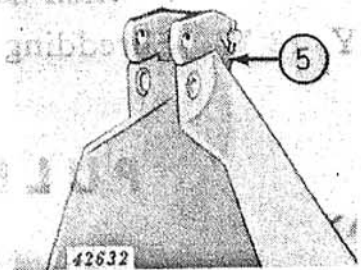
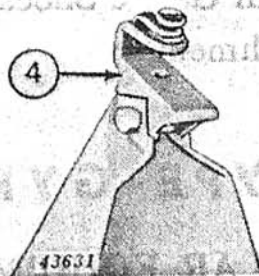
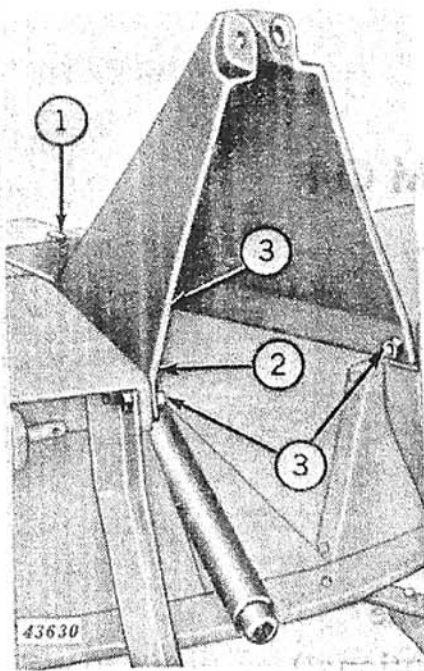

1. Remove clutch cover by pulling back and lifting up on handle.
2. Bolt flange end of power shaft to clutch housing.
3. Bolt mast to frame. Replace clutch cover.
4. When using Gyramor equipped with side wheels or gauge shoes with the No. 800, 800A or 801 Hitch, bolt mast bracket with bolts through sides and back to mast.

5. When using with rear mounted gauge wheel and Model "40" Tri-cycle and "40" Special Tractors, bolt top link connection to top of mast. Make sure connection pivots freely and seats properly on top surface of mast.

NOTE: When using with rear mounted gauge wheel and Model "40" Standard, Utility, or Two-Row Utility Tractor, the top link connection is assembled to the mast when attaching Gyramor to tractor (see pages 10 and 11).

GAUGE SHOES

1. Attach gauge shoes as illustrated. Guide adjusting screw through hole at top.

2. Insert pin through adjusting crank swivel and adjusting screw.

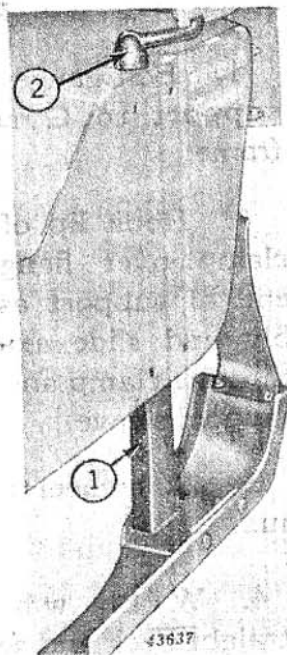

GAUGE SHOE TREAD EXTENSIONS

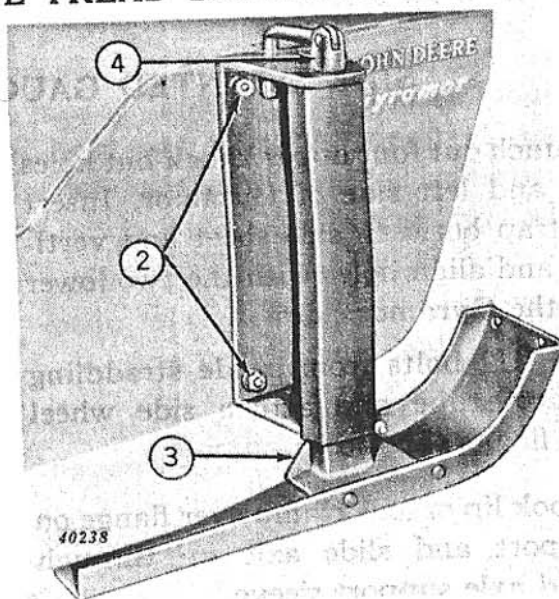
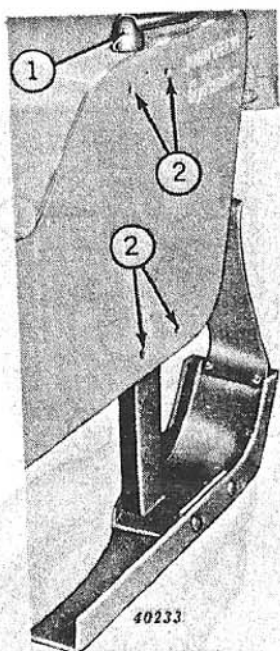

Raise rear wheels of tractor approximately 1 foot using jacks or blocks and raise Gyramor to the highest position through use of the hydraulic system on the tractor.

NOTE: If tractor is not available turn Gyramor on its side changing one shoe and then the other.

Place blocks under gauge shoes to prevent them from dropping down suddenly.

1. Using punch, drive pin from adjusting crank swivel and remove gauge shoe assembly.
2. Punch out knock-out holes at top and bottom of Gyramor side sheets and using U-bolts, attach tread extensions to sides of Gyramor.
3. Insert gauge shoe assembly in tread extensions.
4. Guide adjusting screw through hole at top and insert pin through adjusting crank swivel and adjusting screw.

REAR MOUNTED GAUGE WHEEL

1. Bolt gauge wheel support to Gyramor frame.

2. Hook lip of axle clamp over flange at end of support assembly and slide axle up through clamp and axle support sleeve.

3. Bolt wheel to axle hub.

4. With wheel straight back and set to desired cutting height, tighten axle clamp so lip is midway between the stops. Tighten set screw.

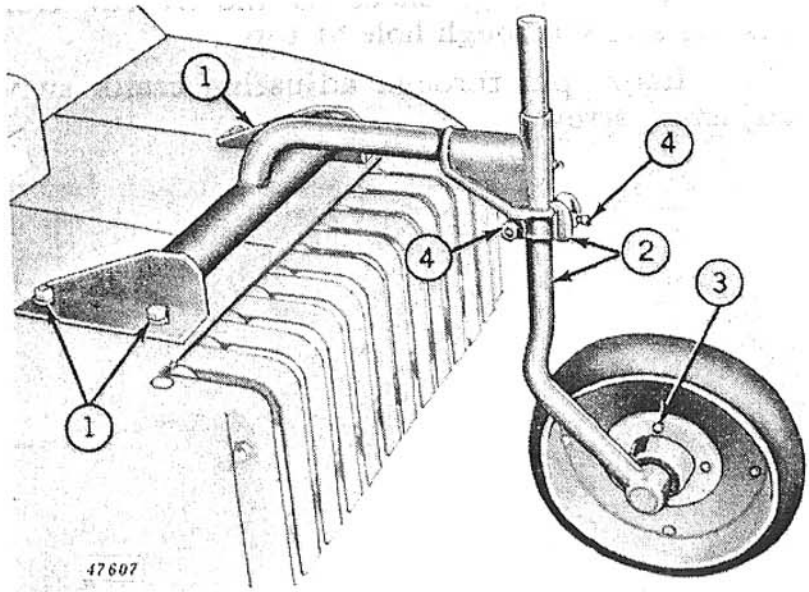

SIDE MOUNTED GAUGE WHEELS

1. Punch out four upper knock-out holes in right and left side of Gyramor. Insert spacer strap between side sheet and vertical tube and align holes with the two lower holes in the Gyramor sides.

Insert "U" bolts from inside straddling the vertical tube and attach side wheel supports flange side down.

2. Hook lip of axle clamp over flange on axle support and slide axle up through clamp and axle support sleeve.

3. Bolt wheels to hubs.

4. With wheels swung in to about 1/2-inch from the Gyramor side, set at the desired cutting height, tighten axle clamp so lip is against rear stop. Tighten set screw.

CAUTION: Make sure wheels will not rub side of frame when Gyramor is in operation.

NOTE: See additional assembly instructions on pages 42 and 43.

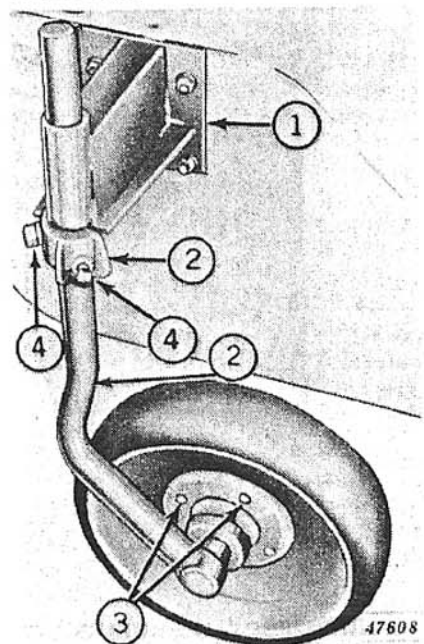

PULL-TYPE GYRAMOR

HITCH, HITCH STAND, MAST, AND LEVELING SCREW

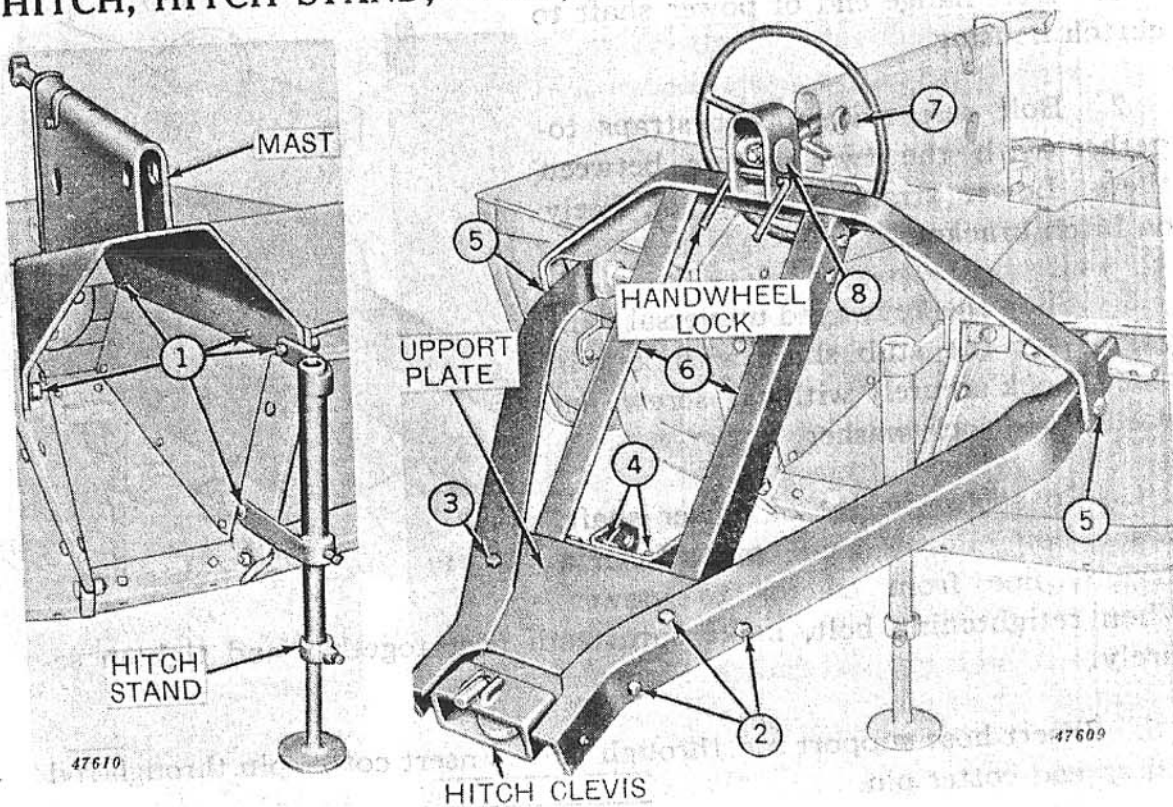

1. Block up Gyramor frame about one foot above ground level and bolt hitch stand and mast to frame.
2. Insert left-hand hitch support angle over Gyramor outer draft pin and bolt hitch support plate to angle. Do not tighten bolts until hitch is completely assembled.
3. Insert right-hand hitch angle over Gyramor outer hitch pin. Place hitch clevis between angles being sure hitch clevis is assembled with the slot for Quik-Tatch pin facing the rear. Bolt right-hand angle to hitch support plate.
4. Bolt power line support bracket to hitch support plate.
5. Bolt upper hitch support angle to right- and left-hand angles.
6. Bolt center support angles to hitch. Tighten all bolts in hitch assembly, securely.
7. Place pivot block in mast and thread leveling screw crank through pivot block.
8. Place pivot block in top of hitch support and, with bearing next to hand wheel, insert leveling screw through pivot block and lock in place with hex. slotted nut and cotter pin.

POWER SHAFT, SHIELD AND HOSE SUPPORT

1. Bolt flange end of power shaft to clutch housing.

2. Bolt serrated support straps together with the two spacers between them. Lower straps must pivot freely on hitch bracket.

3. Slide the keywayed universal joint yoke over the stub shaft with key in place. Lock securely with cap screw, flat washer and lock washer.

4. To adjust height of power shaft, loosen bolt. Power shaft must form a straight line from tractor to mower.

When retightening bolt, make sure teeth nest together and tighten securely.

5. Insert hose support rod through mast. Insert cotter pin through rod and spread cotter pin.

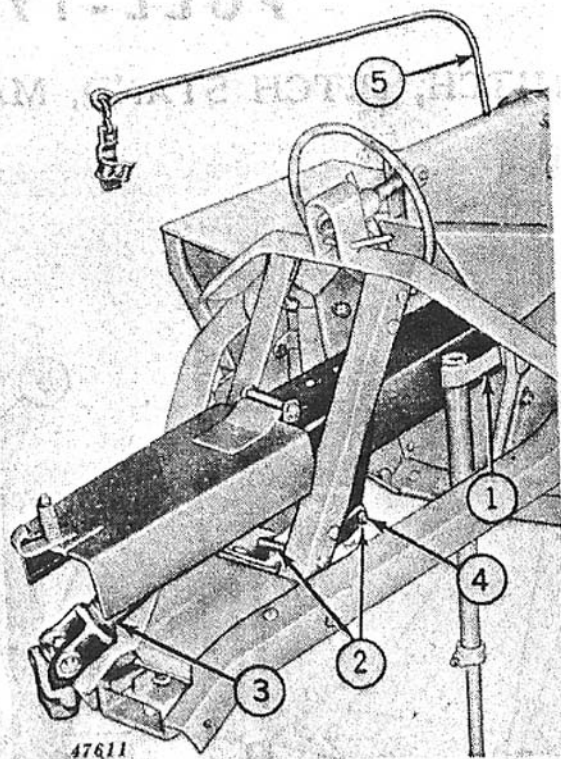

REAR AXLE AND WHEELS

The wheels can be used to the front and side of the Gyramor or to the rear of machine, depending on conditions and the wheel tread desired.

Assembling Wheels at Front and Side (80-Inch Tread Only)

1. Bolt rear axle supports to frame.
2. Place rear axle over supports and bolt clamps to axle supports.
3. Attach cylinder support to rear axle support using drilled pins. Insert and spread cotter pins.
4. Insert pivot block in mast and place cylinder support rod through pivot block, lining up hole in rod with hole in pivot block. Insert pin "A" through rod and pivot block and lock in place with spring locking pin.

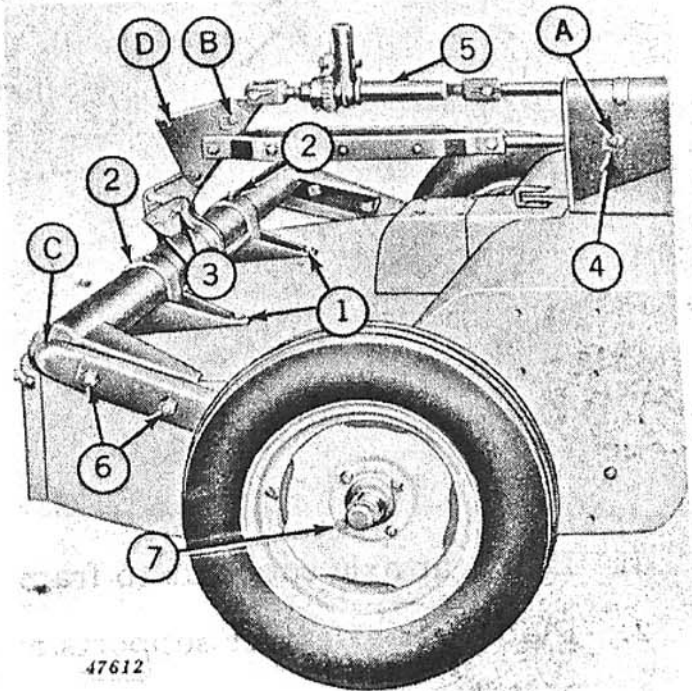

5. Attach Hand-Lift Screw Jack or Powr-Trol cylinder, if available, to facilitate assembling wheels and axles.

6. Insert spacers "C" in axle arm with round head outward and insert bolts through axle and spacer. Tighten bolts securely.

7. Raise axles high enough to bolt wheels to hubs, with valve stem on the outside.

To lock wheels for transporting, when Powr-Trol cylinder is removed, raise wheels to highest position. Remove pin "B" and insert through hole "D."

Assembling Wheels At Rear (80-Inch Tread)

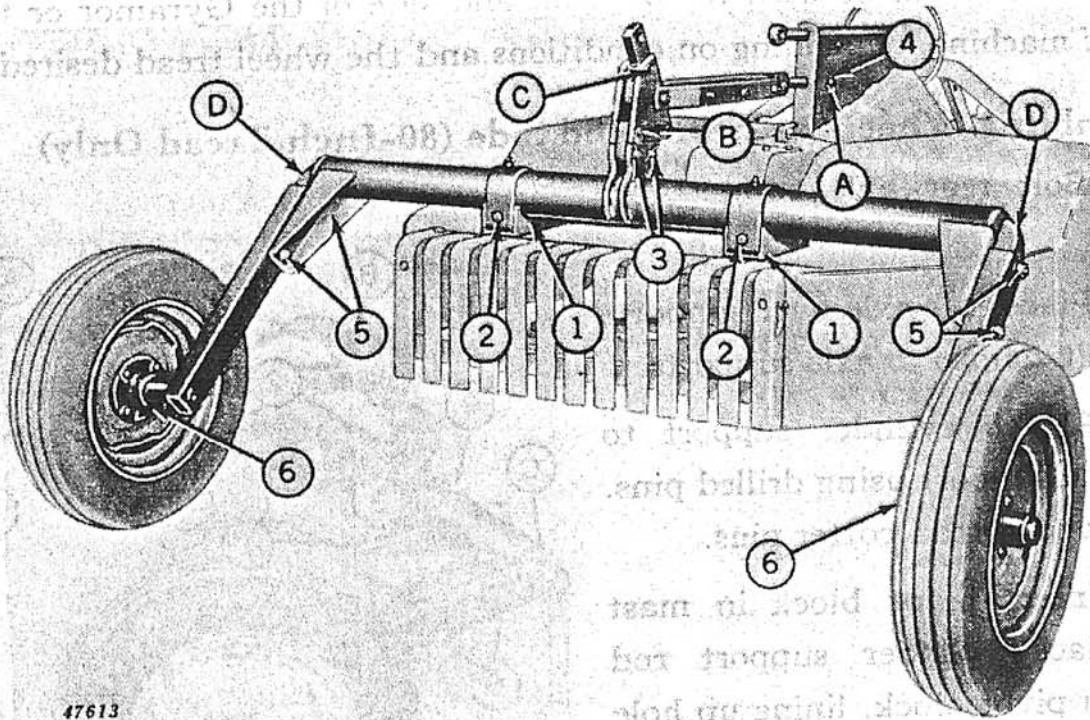

47613

1. Bolt rear axle supports to frame.
2. Place rear axle over supports and bolt clamps to axle supports.
3. Attach cylinder support to rear axle support using pins. Insert and spread cotter pins.
4. Insert pivot block in mast and place cylinder rod through pivot block, lining up hole in rod with hole in pivot block. Insert pin "A" through rod and pivot block and lock in place with spring locking pin. Raise axle high enough to insert pin "B" through cylinder support and rear axle.
5. If Hand Lift Screw Jack or Powr-Trol cylinder is available, attach it to lift mechanism to facilitate assembly. Insert spacers "D" in axles with round head outward and insert bolts through axles and spacers. Tighten bolts securely.

NOTE: See page 41 for setting wheels at 52-1/2-inch, 57-inch, and 75-1/2-inch spacing.

6. Raise axles high enough to bolt wheels to hubs.

When operating machine in field it is necessary to remove pin "A" and insert it through hole "C." This is done while the cylinder or Hand Lift Screw Jack is attached to the machine.

Wheels at Rear—52-1/2-Inch Tread.

1. Insert spacer in axle with round head inward and open side of spacer facing toward axle support plate. Line up holes in spacer with holes in axle and insert bolt through axle and spacer. Tighten bolts securely.

2. Bolt wheels to hubs.

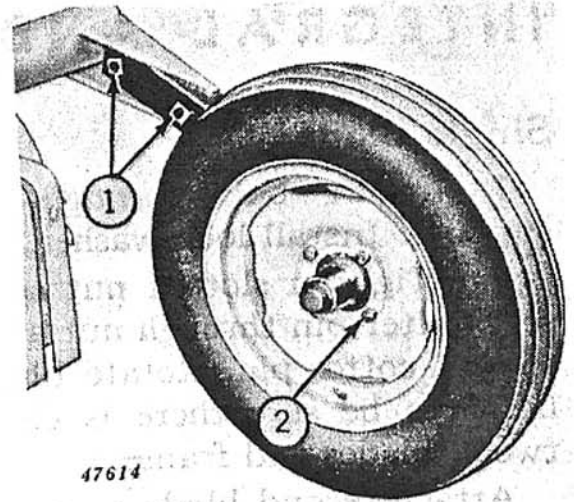

47614

Wheels at Rear—57-Inch Tread.

1. Insert spacer with round head outward. Line up holes in spacer with holes in axle and insert bolts through axle and spacer. Tighten bolts securely.

2. Bolt wheels to hubs.

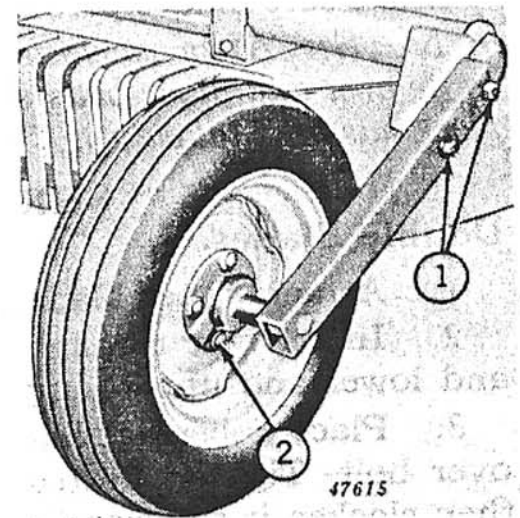

47615

Wheels at Rear—75-1/2-Inch Tread.

1. Insert spacer in axle with round head inward and open side of spacer facing toward axle support plate. Line up holes in spacer with holes in axle and insert bolt through axle and spacer. Tighten bolts securely.

2. Bolt wheels to hubs.

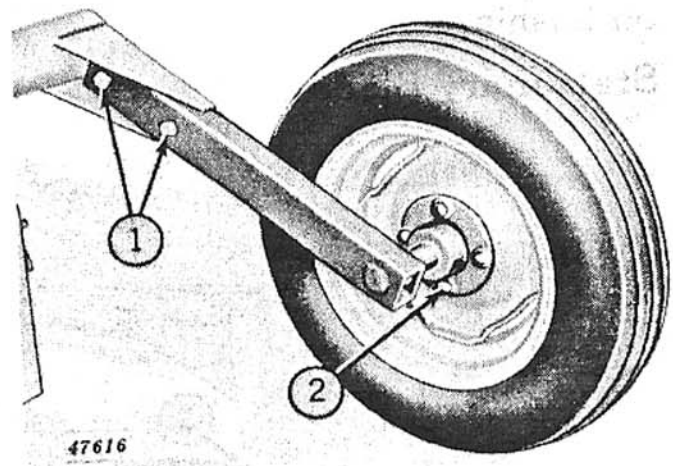

47616

INTEGRAL AND PULL-TYPE GYRAMOR BLADES

Single Blade.

1. Insert bolt through blade and support. Install lock washer.
2. Tighten slotted nut securely. Insert cotter pin through nut and bolt and spread cotter pin. Rotate blade arm by hand to be sure there is clearance between blades and frame.

Attach second blade in same manner.
Make sure blades pivot freely on bolt.

NOTE: After machine has been in operation approximately one hour, knife arm and blade bolts should be retightened; then tightened daily until all slack has been taken up.

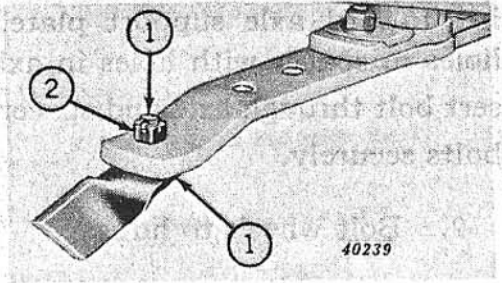

SHREDDER ATTACHMENT

Double Blades.

1. Attach upper blade support.
2. Insert bolt through bottom blade and lower and upper supports.
3. Place upper flat blade and washer over bolt. Tighten slotted nut securely, then slacken it sufficiently to insert cotter pin through nut and bolt and spread cotter pin. Make sure blades pivot freely on bushings.

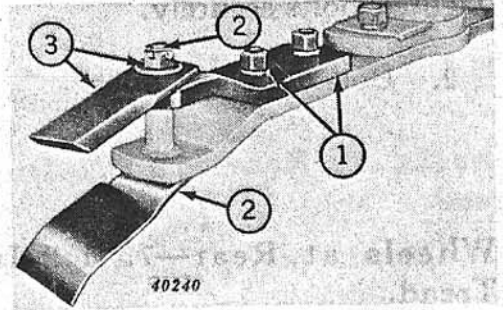

Stationary Blades.

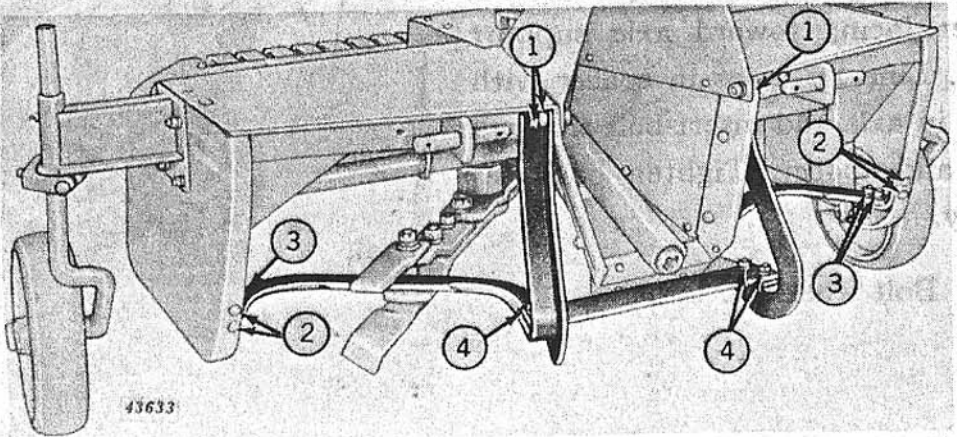

1. Bolt outer right- and left-hand blade supports to frame.
2. Bolt inner right- and left-hand blade supports to frame.
3. Bolt shredding blades to the top of outer and inner blade supports.
4. Bolt connecting strap on top of shredding blades.

NOTE: Rotate blade arm by hand to be sure there is clearance between moving blades, stationary blades, and frame.

CAUTION: Do not use suction or pickup blades in the upper position. Any style blade can be used in lower position.

FRONT SHIELD EXTENSION

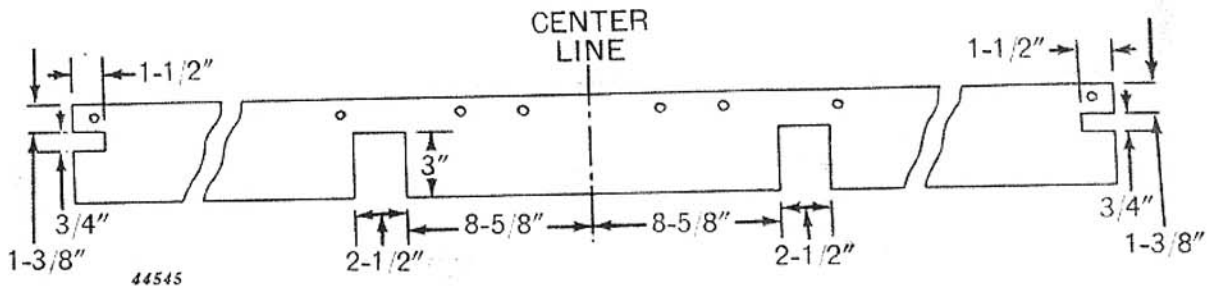

When using the front shield extension with the shredding attachment, it is necessary to cut the belting, as illustrated above, to insure a proper fit.

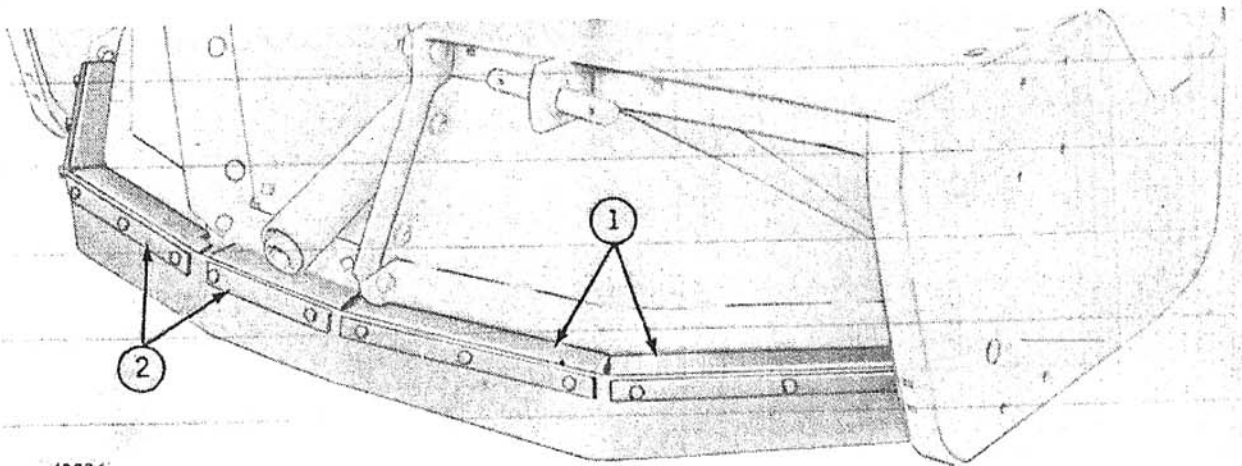

Remove bolts and detach straps and belting from support brackets.

1. Bolt support brackets to Gyramor front shields. Tighten bolts securely.
2. Bolt support straps and belting to support brackets on Gyramor front shields.

Leave bolts loose until belting is completely attached to support brackets, then tighten all bolts securely.

GATHERER

1. Bolt gatherer support angles to frame.
2. Punch out two front lower right- and left-hand knock-out holes in Gyramor frame and bolt gatherer to support angles inserting bottom bolt through support strap.
3. Place one end of U-bolt through support strap and insert U-bolt through frame. Place clamp over U-bolt, then lock washers and nuts, and tighten securely.

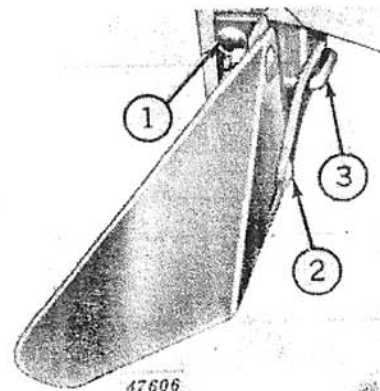

FOR JOHN DEERE DEALER
PARTS DEPARTMENT
ATTENTION!



Your John Deere equipment is designed to be safe. It is built to deliver efficient, dependable service and performance down through the years. You can be sure your John Deere equipment is safe.

Farm Accidents Can Be Prevented with Your Help

NO accident prevention program can be successful without the wholehearted cooperation of the person who is directly responsible for the operation of equipment.

To read accident reports from all over the Country is to be convinced that a large number of accidents can be prevented only by the operator anticipating the result before the accident is caused and doing something about it. No power-driven equipment, whether it be transportation or processing, whether it be on the highway, in the harvest field, or in the industrial plant, can be safer than the man who is at the controls. If farm accidents are to be prevented—and they can be prevented—it will be done by the operators who accept a full measure of their responsibility.

It is true that the designer, the manufacturer, the safety engineer can help; and they will help, but their combined efforts can be wiped out by a single careless act of the operator.

It is said that "the best kind of a safety device is a careful operator." We ask you to be that kind of an operator.

NATIONAL SAFETY COUNCIL

YOUR JOHN DEERE Dealer Offers Double-Barreled

PROTECTION!



Your John Deere Equipment is designed and built to deliver efficient, dependable service and performance down through the years. Yet, when needed, you can rely on your John Deere dealer. He's your full-time working partner; he's there, too, for double-barrel protection for your equipment.

1. SERVICE

If service is required, your John Deere dealer's skilled mechanics can handle it efficiently every time. These mechanics are trained in John Deere working methods; they have proper tools and parts. No other shop in your community offers these advantages.

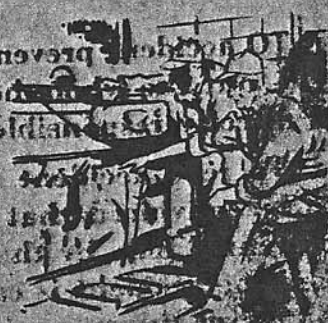

2. PARTS

If parts are needed, you can depend on your John Deere dealer for genuine John Deere parts . . . replacement parts that fit right, wear properly. They're exact duplicates of the parts they replace. Remember . . . only *genuine* John Deere parts deliver 100 per cent John Deere performance . . . the performance you chose when you bought your John Deere equipment.



Yes . . . for parts . . . for service on your John Deere equipment, take it to the man who knows it best . . . your John Deere dealer.



For the **BEST** Service for Your
JOHN DEERE Tractor and Equipment . . .
SEE YOUR JOHN DEERE DEALER









